

Safety of transportable motor-operated electric tools —

Part 1: General requirements

The European Standard EN 61029-1:2000, with the incorporation of amendment A1:2003, has the status of a British Standard

ICS 25.140.20

<http://www.china-gauges.com/>

NO COPYING WITHOUT BSI PERMISSION EXCEPT AS PERMITTED BY COPYRIGHT LAW

National foreword

This British Standard is the official English language version of EN 61029-1:2000, including amendments A11:2003 and A12:2003. It was derived by CENELEC from IEC 61029-1:1990. It supersedes BS EN 61029-1:1996 which will be withdrawn on 2002-09-01.

The CENELEC common modifications have been implemented at the appropriate places in the text. The start and finish of each common modification is indicated in the text by tags [C] [C]. Where a common modification has been introduced by amendment, the tags carry the number of the amendment. For example, the common modifications introduced by CENELEC amendment A11 are indicated by [C11] [C11].

The UK participation in its preparation was entrusted by Technical Committee CPL/61, Safety of household and similar electrical appliances, to Subcommittee CPL/61/6, Portable motor-operated tools, which has the responsibility to:

- aid enquirers to understand the text;
- present to the responsible international/European committee any enquiries on the interpretation, or proposals for change, and keep the UK interests informed;
- monitor related international and European developments and promulgate them in the UK.

A list of organizations represented on this subcommittee can be obtained on request to its secretary.

Cross-references

The British Standards which implement international or European publications referred to in this document may be found in the *BSI Catalogue* under the section entitled “International Standards Correspondence Index”, or by using the “Search” facility of the *BSI Electronic Catalogue* or of British Standards Online.

This publication does not purport to include all the necessary provisions of a contract. Users are responsible for its correct application.

Compliance with a British Standard does not of itself confer immunity from legal obligations.

Summary of pages

This document comprises a front cover, an inside front cover, the EN title page, pages 2 to 84, an inside back cover and a back cover.

The BSI copyright notice displayed in this document indicates when the document was last issued.

This British Standard, having been prepared under the direction of the Electrotechnical Sector Committee, was published under the authority of the Standards Policy and Strategy Committee and comes into effect on 15 October 2000

© BSI 12 December 2003

ISBN 0 580 36394 5

Amendments issued since publication

Amd. No.	Date	Comments
14622	12 December 2003	See national foreword

<http://www.china-gauges.com/>

English version

Safety of transportable motor-operated electric tools — Part 1: General requirements

(includes amendments A11:2003 and A12:2003)

(IEC 61029-1:1990, modified)

Sécurité des machines-outils électriques
semi-fixes —
Partie 1: Règles générales
(inclut les amendements A11:2003 et A12:2003)
(CEI 61029-1:1990, modifiée)

Sicherheit transportabler motorbetriebener
Elektrowerkzeuge —
Teil 1: Allgemeine Anforderungen
(enthält Änderungen A11:2003 und A12:2003)
(IEC 61029-1:1990, modifiziert)

This European Standard was approved by CENELEC on 1998-08-01. Amendment A11 was approved by CENELEC on 2002-10-01 and amendment A12 was approved by CENELEC on 2002-11-01. CENELEC members are bound to comply with the CEN/CENELEC Internal Regulations which stipulate the conditions for giving this European Standard the status of a national standard without any alteration.

Up-to-date lists and bibliographical references concerning such national standards may be obtained on application to the Central Secretariat or to any CENELEC member.

This European Standard exists in three official versions (English, French, German). A version in any other language made by translation under the responsibility of a CENELEC member into its own language and notified to the Central Secretariat has the same status as the official versions.

CENELEC members are the national electrotechnical committees of Austria, Belgium, Czech Republic, Denmark, Finland, France, Germany, Greece, Hungary, Iceland, Ireland, Italy, Luxembourg, Malta, Netherlands, Norway, Portugal, Slovakia, Spain, Sweden, Switzerland and United Kingdom.

CENELEC

European Committee for Electrotechnical Standardization
Comité Européen de Normalisation Electrotechnique
Europäisches Komitee für Elektrotechnische Normung

Central Secretariat: rue de Stassart 35, B-1050 Brussels

© 2000 CENELEC — All rights of exploitation in any form and by any means reserved worldwide for CENELEC members.

Ref. No. EN 61029-1:2000 + A11:2003 + A12:2003 E

Foreword

This European Standard has been prepared by the Technical Committee CENELEC TC 61F, Hand-held and transportable motor operated electric tools.

The text of the International Standard IEC 61029-1 with CENELEC common modifications was submitted to the formal vote and was approved by CENELEC as EN 61029-1 on 1998-08-01.

This European Standard supersedes EN 61029-1:1995.

The following dates were fixed:

- latest date by which the EN has to be implemented at national level
by publication of an identical national standard or by endorsement (dop) 2000-09-01
- latest date by which the national standards conflicting
with the EN have to be withdrawn (dow) 2001-09-01

Part 1 of this standard together with related Parts 2 gives directly and by reference the complete requirements for the specific type of transportable tool defined in the scope.

Other standards to which this European Standard refers are listed in Annex A. This annex lists the valid edition of these documents at the time of issue of this EN. All reference to these standards is however to be understood to be a reference to the latest edition.

This standard is divided into two parts:

- Part 1 General requirements which are common to most transportable electric motor operated tools (for the purpose of this standard referred to simply as tools) which could come within the scope of this standard
- Part 2 Requirements for particular types of tool which either supplement or modify the requirements given in Part 1 to account for the particular hazards and characteristics of these specific tools.

This European Standard has been prepared under a mandate given to CEN/CENELEC by the European Commission and the European Free Trade Association and supports the essential safety requirements of the Machinery Directive.

Compliance with the relevant clauses of Part 1 together with a relevant Part 2 of this standard provides one means of conforming with the essential health and safety requirements of the Directive.

A relevant Part 2 is one in which the type of tool or an accessory which is to be used with such a tool is within the scope of that Part 2.

When a relevant Part 2 does not exist, Part 1 can help to establish the requirements for the tool, but will not by itself provide a means of conforming with the relevant essential health and safety requirements of the Machinery Directive.

Warning: Other requirements arising from other EC Directives can be applicable to the products falling within the scope of this standard.

CEN has proposed standards for industrial machines, which may extend to transportable machines. Although CEN and CENELEC have, where appropriate, used common solutions to provide uniform levels of protection, persons using this standard should check the scope of both this and CEN standards to ensure that a correct standard is used. Where necessary, normative reference is made to these standards in the relevant Part 2.

Annexes designated "normative" are part of the body of this standard. Annexes designated "informative" are given only for information. In this standard, annexes A, B, C, D and ZB are normative and annexes IA and ZA are informative.

NOTE In this standard the following print types are used:

- Requirements proper;
- *Test specifications*;
- Explanatory matter.

Foreword to amendment A11

This amendment to the European Standard EN 61029-1:2000 was prepared by the Technical Committee CENELEC TC 61F, Safety of hand-held and transportable motor-operated electric tools.

The text of the draft was submitted to the Unique Acceptance Procedure and was approved by CENELEC as amendment A11 to EN 61029-1:2000 on 2002-10-01.

The following dates were fixed:

- latest date by which the amendment has to be implemented
at national level by publication of an identical national standard
or by endorsement (dop) 2003-12-01
- latest date by which the national standards conflicting
with the amendment have to be withdrawn (dow) 2005-10-01

Foreword to amendment A12

This amendment to the European Standard EN 61029-1:2000 was prepared by the Technical Committee CENELEC TC 61F, Safety of hand-held and transportable motor-operated electric tools.

The text of the draft was submitted to the Unique Acceptance Procedure and was approved by CENELEC as amendment A12 to EN 61029-1:2000 on 2002-11-01.

The following dates were fixed:

- latest date by which the amendment has to be implemented
at national level by publication of an identical national standard
or by endorsement (dop) 2003-12-01
- latest date by which the national standards conflicting
with the amendment have to be withdrawn (dow) 2005-11-01

Introduction

This European Standard is divided into two parts:

Part 1: General requirements, comprising clauses of a general character.

Part 2: Particular requirements, dealing with particular types of tool.

☐ The requirements in a clause in a Part 2 supplement or modify the corresponding clauses in Part 1. ☐

Where the text of a Part 2 indicates an "addition" to or a "replacement" of the relevant requirement, test specification or explanation of Part 1, these changes are made to the relevant text of Part 1, which then becomes part of the standard. Where no change is necessary, the words "This clause of Part 1 is applicable" are used in the Part 2.

☐ This standard follows the overall requirements of EN 292-1 and 292-2. ☐

1 Scope

☐ 1.1 This standard consists in Part 1 and Part 2 and applies to electric motor-operated or magnetically-driven tools, intended for indoor and for outdoor use, which have all the following characteristics: ☐

- a) easily moved by one person, simple devices to facilitate transportation may be incorporated, e.g. handles, wheels and the like;
- b) used in a safe stationary position with or without fixing, e.g. fast clamping devices, bolting and the like;
- c) used under the control of an operator;
- d) not intended for continuous production or production line use;
- e) intended to be connected to electric supply by a flexible cord and a plug;
- f) maximum rated voltage not exceeding 250 V single-phase, a.c. or d.c., or 440 V three-phase, a.c.;
- g) maximum rated input not exceeding 2500 W, for single-phase a.c. or d.c., and 4000 W for three-phase a.c.

☐ These tools are commonly known as "transportable motor-operated electric tools", hereinafter referred to, in the text, as tools.

Examples of these tools are: Circular saws, band saws, planers, thicknessers, radial arm saws, spindle moulders, fret saws, jig saws, mitre/chop saws, wood lathes, belt sanders, disc sanders, thicknessers-planers, chain mortisers, multipurpose machines, combing machines, metal lathes, bench grinders, bench drilling machines, pipe threaders, pipe benders, pipe saws, key cutting machines, sharpening machines, sheet metal shears, concrete drills, concrete saws, wood shredders, pipe cleaners ☐

☐ This standard applies also to transportable motor operated tools intended to be connected to a water supply. ☐

☐ 1.2 This standard does not apply to:

- electric motor-operated household and similar electrical appliances according to EN 60335-1;
- hand-held electric motor-operated tools according to EN 50144-1;
- small low voltage transformer operated bench tools intended for model making;
- machines for preparing or processing food;
- tools used in explosive atmospheres;
- additional driving mechanisms required for external cooling and dust extraction/collection systems. ☐

2 Definitions

For the purpose of this European Standard, the following definitions apply.

☐ Where the terms "voltage" and "current" are used, they imply the r.m.s. value unless otherwise specified. ☐

2.1

rated voltage

voltage (for three-phase supply, the voltage between phases) assigned to the tool by the manufacturer

2.2

rated voltage range

voltage range assigned to the tool by the manufacturer, expressed by its lower and upper limits

2.3

working voltage

maximum voltage to which the part under consideration can be subjected when the tool is operating at its rated voltage and under normal conditions of use

☐ Normal conditions of use include changes of voltage within the tool imposed by likely occurrences such as the operation of a circuit breaker or the failure of a lamp.

When determining the working voltage, the effect of possible transient voltages on the supply mains is ignored. ☐

2.4

rated input

input in watts at rated voltage or the mean of the rated voltage range assigned to the tool by the manufacturer

2.5

rated current

current at rated voltage or at the mean of the rated voltage range assigned to the tool by the manufacturer

NOTE If no current is assigned to the tool, the rated current for the purpose of this standard is determined by calculation from the rated input and the rated voltage and/or by measuring the current when the tool is operating at rated voltage under normal load and at normal operating temperature.

2.6

rated frequency

frequency assigned to the tool by the manufacturer

2.7

rated frequency range

frequency range assigned to the tool by the manufacturer, expressed by its lower and upper limits

2.8

rated no-load speed

no-load speed at rated voltage or at the upper limit of the rated voltage range, assigned to the tool by the manufacturer

2.9

detachable flexible cord

flexible cord, for supply or other purposes, intended to be connected to the tool by means of a suitable appliance coupler

☐ NOTE Cord sets are covered by EN 60799; appliance couplers for household and similar general purposes by EN 60320-1. ☐

2.10

power supply cord

flexible cord, for supply purposes, fixed to, or assembled with, the tool according to one of the following methods:

- **type X attachment:** Method of attachment such that the flexible cord can easily be replaced, without the aid of special purpose tools, by a flexible cord not requiring any special preparation;
- **type M attachment:** Method of attachment such that the flexible cable or cord can easily be replaced, without the aid of special purpose tools, by a special cord with, for example, a moulded-on cord or crimped terminations.

2.11

basic insulation

insulation applied to live parts to provide basic protection against electric shock

NOTE Basic insulation does not necessarily include insulation used exclusively for functional purposes.

2.12

supplementary insulation

independent insulation applied in addition to the basic insulation, in order to ensure protection against electric shock in the event of a failure of the basic insulation

2.13

double insulation

insulation comprising both basic insulation and supplementary insulation

2.14

reinforced insulation

single insulation system applied to live parts, which provides a degree of protection against electric shock equivalent to double insulation under the conditions specified in this standard

☐ "Single insulation system" does not imply that the insulation must be one homogeneous piece. It may comprise several layers which cannot be tested singly as supplementary or basic insulation. ☐

2.15

class I tool

tool in which protection against electric shock does not rely on basic insulation only, but which includes an additional safety precaution in such a way that means are provided for the connection of accessible conductive parts to the protective (earthing) conductor in the fixed wiring of the installation in such a way that accessible conductive parts cannot become live in the event of a failure of the basic insulation

NOTE Class I tools may have parts with double insulation or reinforced insulation or parts operating at safety extra-low voltage.

☐ For tools intended for use with a flexible cord, the provision includes a protective conductor as part of the flexible cord. ☐

2.16

class II tool

tool in which protection against electric shock does not rely on basic insulation only, but in which additional safety precautions, such as double insulation or reinforced insulation, are provided, there being no provision for protective earthing or reliance upon installation conditions.

Such a tool may be of one of the following types:

- a) a tool having a durable and substantially continuous enclosure of insulating material which envelops all metal parts, with the exception of small parts, such as nameplates, screws and rivets, which are isolated from live parts by insulation at least equivalent to reinforced insulation; such a tool is called an insulation-encased class II tool;
- ☐ b) a tool having a substantially continuous metal enclosure, in which double insulation is used throughout, except for those parts where reinforced insulation is used, because the application of double insulation is manifestly impracticable; such a tool is called a metal-encased class II tool; ☐
- c) a tool which is a combination of types a) and b).

2.17

class III tool

tool in which protection against electric shock relies on supply at safety extra-low voltage (SELV) and in which voltages higher than those of SELV are not generated

☐ Text deleted ☐

2.18

extra-low voltage

voltage supplied from a source within the tool and, when the tool is operated at its rated voltage, not exceeding 42 V between conductors and between conductors and earth or, for three-phase supply, not exceeding 24 V between conductors and neutral, the extra-low voltage circuit being separated from other circuits by basic insulation only

2.19

safety extra-low voltage (SELV)

nominal voltage not exceeding 42 V between conductors and between conductors and earth or, for three-phase supply, not exceeding 24 V between conductors and neutral, the no-load voltage not exceeding 50 V and 29 V respectively

NOTE 1 When SELV is obtained from the supply mains, it must be through a safety isolating transformer or a convertor with separate windings.

NOTE 2 The voltage limits specified are based on the assumption that the safety isolating transformer is operated at its rated supply voltage.

☐

Limitations to voltages lower than 50 V a.c. should be specified in the particular standards, especially when direct contact with live parts is involved.

Separation from the mains by protective impedance is excluded. ☐

2.20

safety isolating transformer

transformer the input winding of which is electrically separated from the output windings by an insulation at least equivalent to double insulation or reinforced insulation, and which is designed to supply a distribution circuit, a tool or other equipment at safety extra-low voltage

2.21

normal load

load to be applied to a tool so that the stress imposed corresponds to that occurring under normal conditions of use, any marking of short-time or intermittent operation being observed and, unless otherwise specified, heating elements, if any, being operated as in normal use

NOTE The normal load is based on the rated voltage or on the upper limit of the rated voltage range.

2.22

rated operating time

operating time assigned to the tool by the manufacturer

2.23

continuous operation

operation under normal load for an unlimited period

2.24

short-time operation

operation under normal load for a specified period, starting from cold, the intervals between each period of operation being sufficient to allow the tool to cool down approximately to room temperature

2.25

intermittent operation

operation in a series of specified identical cycles, each cycle being composed of a period of operation under normal load followed by a rest period with the tool running idle or switched off

<http://www.china-gauges.com/>

2.26

non-detachable part

part which can only be removed with the aid of a tool

☐ Where expressions such as “with the aid of a tool” occur, the word tool means a hand tool, for example screwdrivers, which may be used to operate a screw or other means of fixing ☐

2.27

detachable part

part which can be removed without the aid of a tool

2.28

thermal cut-out

device which, during abnormal operation, limits the temperature of a tool, or of parts of it, by automatically opening the circuit or by reducing the current, and which is so constructed that its setting cannot be altered by the user

2.29

non-self-resetting thermal cut-out

thermal cut-out which requires resetting by hand, or replacement of a part, in order to restore the current

2.30

creepage distance

shortest path between two conductive parts, or between a conductive part and the bounding surface of the tool, measured along the surface of the insulating material

2.31

clearance

shortest distance between two conductive parts, or between a conductive part and the bounding surface of the tool, measured through air

NOTE The bounding surface of the tool is the outer surface of the enclosure, considered as though metal foil were pressed into contact with accessible surfaces of insulating material.

2.32

all-pole disconnection

for single-phase a.c. tools and for d.c. tools, disconnection of both supply conductors by a single switching action or, for tools to be connected to more than two supply conductors, disconnection of all supply conductors, except the earthed (grounded) conductor, by a single switching action

NOTE The protective earthing conductor is not a supply conductor.

2.33

accessible part or accessible surface

part or surface which can be touched by means of the standard test finger shown in Figure 1

☐ For accessible metal parts, it includes any other metal part which is in electrical contact with such parts

The term body includes all accessible metal parts, shafts of handles, knobs, grips and the like and metal foil in contact with all surfaces of insulating material; it does not include inaccessible metal parts ☐

2.34

power circuit

circuit which contains electrical equipment intended for generation, transformation, distribution or consumption of electric energy

2.35

control circuit

auxiliary circuit which is used to control electrical equipment

2.36

control device

device, for example push-buttons, selector switches, which is used to control, by hand, the function of the tool

2.37

PRCD

portable residual current device

3 General requirement

Tools shall be so designed and constructed that in normal use they function safely and cause no danger to persons or to the surroundings, even in the event of such careless use as may occur in normal service.

The materials used for the construction of the tool should not introduce additional hazards during the use or disposal of the tool.

In general, compliance is checked by carrying out all the relevant tests.

4 General notes on tests

4.1 *Tests according to this standard are type tests.*

4.2 *Unless otherwise specified, tests are carried out on a single test sample as delivered, the said sample withstanding all the relevant tests.*

Where the tool is designed for varying supply voltages, for both a.c. and d.c. and for different speeds, etc., then more than one sample may be required.

When testing a tool in accordance with EN 60529 a further test sample is required when the type of protection concerned involves a higher degree of severity than IP20.

Testing of components may necessitate the submission of additional samples of the said components. When the submission of such samples is necessary, they should be submitted together with the tool.

4.3 *Unless otherwise specified, tests are carried out in the order of the clauses in which they are given in this standard.*

Prior to testing, the tool shall be operated at rated voltage or at the lower limit of its rated voltage range in order to verify that it is in working order.

4.4 *The tests are carried out with the tool, or any movable part of it, placed in the most unfavourable position that may occur in normal use.*

4.5 *If the test results are influenced by the temperature of the ambient air, the room temperature is, in general, maintained at $20\text{ }^{\circ}\text{C} \pm 5\text{ }^{\circ}\text{C}$. If, however, the temperature attained by any part is limited by a temperature sensitive device, or is influenced by the temperature at which a change of state occurs, for example the temperature of boiling water, the room temperature is, in case of doubt, maintained at $23\text{ }^{\circ}\text{C} \pm 2\text{ }^{\circ}\text{C}$.*

4.6 *Tools for a.c. only are tested with a.c., at rated frequency, if marked; those for d.c. only are tested with d.c. and those for a.c./d.c. are tested at the more unfavourable supply.*

Tools for a.c. which are not marked with rated frequency or are marked with a frequency range of 50 Hz to 60 Hz are tested with either 50 Hz or 60 Hz, whichever is the national frequency.

Tools marked with a rated frequency range other than 50 Hz to 60 Hz are tested at the most unfavourable frequency within the range.

Tools designed for more than one rated voltage are tested at the most unfavourable voltage.

Unless otherwise specified, tools designed for one or more rated voltage ranges are tested at the most unfavourable voltage within the relevant range.

When it is specified, for tools marked with a rated voltage range, that the supply voltage is equal to the rated voltage multiplied by a factor, the supply voltage is equal to:

- *the upper limit of the rated voltage range multiplied by this factor, if greater than 1;*

<http://www.china-gauges.com/>

- the lower limit of the rated voltage range multiplied by this factor, if smaller than 1.

☐ Where reference is made to the maximum or minimum rated input, the rated input related to the upper limit or lower limit respectively of the rated voltage range is meant. ☐

When testing tools for d.c. only, the possible influence of polarity on the operation of the tools is taken into consideration.

☐ If the tool is designed for more than one rated voltage or rated voltage range, it may be necessary to make some of the tests at the minimum, the mean and the maximum values of the rated voltage or the rated voltage range in order to establish the most unfavourable voltage. ☐

4.7 Tools for which alternative heating elements or accessories are available are tested in accordance with the relevant Part 2, with those elements or accessories which give the most unfavourable results, provided that the elements or accessories used are within the tool manufacturer's specification.

☐ 4.8 If, in normal use, the heating element cannot be operated unless the motor is running, the element is tested with the motor running. If the heating element can be operated without the motor running, the element is tested with or without the motor running, whichever is the more unfavourable. Heating elements incorporated in the tool are connected to a separate supply unless otherwise specified, and tested according to EN 60335-1. ☐

4.9 Unless otherwise specified, tools provided with a regulating device or similar control are tested with these controls adjusted to their most unfavourable setting, if the setting can be altered by the user.

☐ If the adjusting means of the control is accessible without the aid of a tool, this subclause applies whether the setting can be altered by hand or with the aid of a tool; if the adjusting means is not accessible without the aid of a tool, this subclause applies only if the setting can be altered by hand. ☐

NOTE Adequate sealing is regarded as preventing alteration of the setting by the user.

4.10 When the conditions of normal load are specified in Part 2, the tool is loaded according to these conditions, irrespective of any marking of short-time or intermittent operation, unless it is evident from the design of the tool that these conditions will not occur in normal use.

When the conditions of normal load are not specified in Part 2, the tool is loaded according to the manufacturer's instructions; in the absence of such instructions, the tool is operated continuously at a load such that rated input is attained.

For accessories performing a function which is within the scope of a Part 2, the tests are made in accordance with that Part 2.

For other accessories, the tests are made in accordance with the manufacturer's instructions; in the absence of such instructions, the tool is operated continuously at a load such that rated input is attained.

Electronic speed control devices are set for the highest speed.

☐ Text deleted ☐

4.11 When the normal load or the loading conditions are not specified in a Part 2, only the test at rated input applies.

4.12 If a torque is to be applied, the method of loading is chosen so as to avoid additional stresses, such as those caused by a side thrust. Additional loads necessary for the correct operation of the tool are, however, taken into consideration.

4.13 Tools intended to be operated at safety extra-low voltage are tested together with their supply transformer if this is normally sold with the tool.

4.14 For the purpose of clauses 8, 15, 23 and 25, parts separated from live parts by double insulation or reinforced insulation are not regarded as likely to become live in the event of an insulation fault; connection of accessible metal parts to an earthing terminal or earthing contact does not remove the necessity for carrying out these tests.

4.15 *If class I tools have accessible conductive parts which are not connected to an earthing terminal and are not separated from live parts by an intermediate metal part which is connected to an earthing terminal, such parts are checked for compliance with the appropriate requirements specified for class II tools.*

4.16 *Unless otherwise specified, if class I or class II tools have parts operating at safety extra-low voltage, such parts are checked for compliance with the appropriate requirements specified for class III tools.*

4.17 *For tools incorporating electronic circuits, see Annex C.*

5 Rating

5.1 The maximum rated voltage is:

- 250 V for single-phase a.c. or d.c. tools;
- 440 V for three-phase tools.

Compliance is checked by inspection of the marking.

For class III tools the preferred values of the rated voltage are 24 V and 42 V.

6 Classification

Tools are classified.

6.1 According to protection against electric shock:

- class I tools;
- class II tools;
- class III tools.

6.2 According to degree of protection against ingress of foreign bodies and moisture in accordance with EN 60529.

7 Marking and information for use

7.1 Tools shall be marked with:

- rated voltage(s) or rated voltage range(s) in volts;
- symbol for nature of supply, if applicable;
- rated frequency or rated frequency range, in hertz, unless the tool is designed for d.c. only or for a.c. of both 50 Hz and 60 Hz;
- rated input in W or kW, or rated current in amperes;
- rated current in A, if greater than 10 A;
- manufacturer's or responsible vendor's name, trade mark or identification mark;
- manufacturer's address or country of origin;
- manufacturer's or responsible vendor's model or type reference and serial number, if any;
- rated operating time, or rated operating time and rated resting time, in h, min or s, if applicable;
- symbol for class II construction, for class II tools only;
- symbol for degree of protection against foreign bodies and moisture if greater than IP20;
- any mandatory mark showing compliance with legislation by reference to this standard.

Tools for star-delta connection should be clearly marked with the two voltages (e.g. 230 Δ /400 V).

The rated input or current to be marked on the tool is the total maximum input or current that can be on circuit at the same time.

Ⓒ If a tool has alternative components which can be selected by a control device, the rated input is that corresponding to the highest loading possible.

Additional markings are allowed, provided that they do not give rise to misunderstanding. If the motor of a tool is marked separately, the marking of the tool and that of the motor should be such that there can be no doubt with regard to the rating and manufacturer of the tool itself. Ⓒ

7.2 Tools for short-time operation or intermittent operation shall be marked with rated operating time, or rated operating time and rated resting time respectively, unless the operating time is limited by the construction of the tool or by the description of normal load given in Part 2.

The marking of short-time operation or intermittent operation shall correspond to normal use.

The marking of intermittent operation shall be such that the rated operating time precedes the rated resting time, both markings being separated by an oblique stroke.

Ⓒ 7.3 For tools with heating elements incorporated, the complete marking for heating elements required in EN 60335-1 shall, in addition, be given on the marking plate of the tool. Ⓒ

7.4 If the tool can be adjusted to suit different rated voltages or different rated inputs, the voltage or input to which the tool is adjusted shall be easily and clearly discernible.







This requirement does not apply to tools for star-delta connection.

Ⓒ For tools where frequent changes in voltage setting are not required, this requirement is deemed to be met if the rated voltage or the rated input to which the tool is adjusted, can be determined from a wiring diagram fixed to the tool; the wiring diagram may be on the inside of a cover which has to be removed to connect the supply conductors. This diagram may be on a card which is riveted to the cover or on a paper or similar label secured to the cover by an adhesive but it shall not be on a label loosely attached to the tool. Ⓒ

7.5 For tools marked with more than one rated voltage or rated voltage range, the rated input for each of these voltages or ranges shall be marked.

The upper and lower limits of the rated input shall be marked on the tool so that the relation between input and voltage appears distinctly, unless the difference between the limits of a rated voltage range does not exceed 10 % of the mean value of the range, in which case the marking for rated input may be related to the mean value of this range.

7.6 When symbols are used, they shall be as follows:

V	volts
A	amperes
Hz	hertz
W	watts
kW	kilowatts
μ F	microfarads
l	litres
kg	kilograms
N/cm ²	newtons per square centimetre
Pa	pascals
h	hours
min	minutes
s	seconds
	alternating current
	three-phase alternating current
	three-phase alternating current with neutral
	direct current
n_0	no-load speed
	class II tools
IPXX	degree of protection
 min ⁻¹ or .../min	revolutions or reciprocations per minute 

The symbol for nature of supply shall be placed next to the marking for rated voltage.

The dimensions of the symbol of class II shall be such that the length of the sides of the outer square is about twice the length of the sides of the inner square.

The length of the sides of the outer square shall not be less than 5 mm.

The symbol for class II tools shall be so placed that it will be obvious that it is a part of the technical information and is unlikely to be confused with any other marking.

7.7 Terminals intended exclusively for the neutral conductor shall be marked with the letter N.

Earthing terminals shall be marked with the symbol .

This marking shall not be positioned on screws, removable washers or other parts which might be removed and forgotten when conductors are connected.

7.8 The different positions of regulating devices and different positions of switches on tools shall be indicated by numerals, letters, or other visual means.

If figures are used for indicating the different positions, the "OFF" position shall be indicated by the symbol "0" and the position for a greater output, input, speed, etc. shall be indicated by a higher numeral or appropriate symbol.

Where push-buttons are used the "OFF" position shall be marked with the figure "0" and the actuator shall, in addition, be red.

The "ON" position shall be marked with the Figure "I" and the actuator may be any colours except red.

Switches without locking means need not be marked, if their intended operation is obvious.

Manual reset buttons of thermal cut-outs incorporated in motors are exempt from the requirements of this subclause provided these cannot be mistaken for main controls.

7.9 Marking shall be easily legible and durable.

Marking specified in 7.1 to 7.12 shall be on a main part of the tool in such a way that it is clearly discernible when the tool is ready for use.

☐ Self-adhesive labels glued in recesses in the body of the tool or on a surface where they cannot be damaged during normal use are allowed for tools with degree of protection IPX0. ☐

Marking on, and indications for, switches, thermostats, thermal cut-outs and other control devices shall be placed in the vicinity of these components; they shall not be placed on removable parts if these parts can be replaced in such a way that the marking is misleading.

Compliance is checked by inspection and by rubbing the marking by hand for 15 s with a piece of cloth soaked in water and then for a further 15 s with a piece of cloth soaked in petroleum spirit.

After all the tests of this standard the marking shall be easily legible; it shall not be possible to remove marking plates easily and they shall show no curling.

☐ *The petroleum spirit to be used for the test is aliphatic solvent hexane having a maximum aromatics content of 0,1% by volume, a kauri-butanol value of 29, an initial boiling point of approximately 65 °C, a dry point of approximately 69 °C and a specific mass of approximately 0,66 kg/l.* ☐

7.10 Regulating devices and the like, intended to be adjusted during operation shall be provided with an indication for the direction of adjustment to increase or to decrease the value of the characteristic being adjusted.

☐ An indication of + and - is considered to be sufficient.

The requirement does not apply to a regulating device provided with an adjusting means if its "fully-on" position is opposite to its "OFF" position.

The indication for the different positions of the operating means of a control device need not be placed on the device itself. ☐

7.11 Unless it is obviously unnecessary, switches shall be marked or placed so as to indicate clearly which part of the tool they control.

Indications used for this purpose shall wherever practicable be comprehensible without a knowledge of languages, national standards, etc.

7.12 Tools to be connected to more than two supply conductors shall be provided with a connection diagram, fixed to the tool, unless the correct mode of connection is obvious.

☐ The correct mode of connection is deemed to be obvious if the terminals for the supply conductors are indicated by arrows pointing towards the terminals. The earthing conductor is not a supply conductor.

For tools for star-delta connection, the wiring diagram should show how the windings are to be connected.

The connection diagram may be that referred to in 7.4. ☐

7.13 A handbook or information sheet to cover the subjects listed below, shall be provided with the tool by the manufacturer or supplier. It shall be written in the official language(s) of the country in which the tool is sold.

The subjects are:

- a) Installation instructions
 - 1 - Unpacking and assembly.
 - 2 - Setting-up or fixing tool in a stable position.
 - 3 - Connection to power supply, cabling, fusing, socket-type and earthing requirements.
 - 4 - Illustrated description of functions.
 - 5 - Limitations on ambient conditions.
 - 6 - List of contents.
- b) Operating instructions
 - 1 - Setting and testing.
 - 2 - Tool changing.
 - 3 - Clamping of work.
 - 4 - Limits on size of work piece.
 - 5 - General instructions for use.
- c) Safety precautions
 - 1 - Precautions and use of PPE.
 - 2 - Special safety precautions.
 - 3 - Dust extraction.
 - 4 - Guards, security and adjustment.
 - 5 - General safety instructions.

These shall consist of the following text:

"WARNING ! When using electric tools basic safety precautions should always be followed to reduce the risk of fire, electric shock and personal injury including the following.

Read all these instructions before attempting to operate this product and save these instructions".

- d) Maintenance and servicing
 - 1 - Regular cleaning, maintenance and lubrication.

(which shall include the warning "Remove the plug before carrying out any adjustment, servicing or maintenance").
 - 2 - Servicing by manufacturer or agent; list of addresses.
 - 3 - List of user replaceable parts.
 - 4 - Special tools which may be required. 

C e) Safe operation

- 1 - Keep work area clear
 - Cluttered areas and benches invite injuries.
- 2 - Consider work area environment
 - Do not expose tools to rain.
 - Do not use tools in damp or wet locations.
 - Keep work area well lit.
 - Do not use tools in the presence of flammable liquids or gases.
- 3 - Guard against electric shock
 - Avoid body contact with earthed or grounded surfaces (e.g. pipes, radiators, ranges, refrigerators).
- 4 - Keep other persons away
 - Do not let persons, especially children, not involved in the work touch the tool or the extension cord and keep them away from the work area.
- 5 - Store idle tools
 - When not in use, tools should be stored in a dry locked-up place, out of reach of children.
- 6 - Do not force the tool
 - It will do the job better and safer at the rate for which it was intended.
- 7 - Use the right tool
 - Do not force small tools to do the job of a heavy duty tool.
 - Do not use tools for purposes not intended; for example do not use circular saws to cut tree limbs or logs.
- 8 - Dress properly
 - Do not wear loose clothing or jewellery, they can be caught in moving parts.
 - Non-skid footwear is recommended when working outdoors.
 - Wear protective hair covering to contain long hair.
- 9 - Use protective equipment
 - Use safety glasses.
 - Use face or dust mask if working operations create dust.
- 10 - Connect dust extraction equipment
 - If the tool is provided for the connection of dust extraction and collecting equipment, ensure these are connected and properly used.
- 11 - Do not abuse the cord
 - Never yank the cord to disconnect it from the socket. Keep the cord away from heat, oil and sharp edges.
- 12 - Secure work
 - Where possible use clamps or a vice to hold the work. It is safer than using your hand.
- 13 - Do not overreach
 - Keep proper footing and balance at all times. **C**

14 - Maintain tools with care

- Keep cutting tools sharp and clean for better and safer performance.
- Follow instruction for lubricating and changing accessories.
- Inspect tool cords periodically and if damaged have them repaired by an authorized service facility.
- Inspect extension cords periodically and replace if damaged.
- Keep handles dry, clean and free from oil and grease.

15 - Disconnect tools

- When not in use, before servicing and when changing accessories such as blades, bits and cutters, disconnect tools from the power supply.

16 - Remove adjusting keys and wrenches

- Form the habit of checking to see that keys and adjusting wrenches are removed from the tool before turning it on.

17 - Avoid unintentional starting

- Ensure switch is in "off" position when plugging in.

18 - Use outdoor extension leads

- When the tool is used outdoors, use only extension cords intended for outdoor use and so marked.

19 - Stay alert

- Watch what you are doing, use common sense and do not operate the tool when you are tired.

20 - Check damaged parts

- Before further use of tool, it should be carefully checked to determine that it will operate properly and perform its intended function.
- Check for alignment of moving parts, binding of moving parts, breakage of parts, mounting and any other conditions that may affect its operation.
- A guard or other part that is damaged should be properly repaired or replaced by an authorized service centre unless otherwise indicated in this instruction manual.
- Have defective switches replaced by an authorized service centre.
- Do not use the tool if the switch does not turn it on and off.

21 - Warning

- The use of any accessory or attachment other than one recommended in this instruction manual may present a risk of personal injury.

22 - Have your tool repaired by a qualified person

- This electric tool complies with the relevant safety rules. Repairs should only be carried out by qualified persons using original spare parts, otherwise this may result in considerable danger to the user.

The following information shall also be given:

- The name and address of the manufacturer;
- The manufacturer's model or type reference;
- A repeat of the safety markings (e.g. maximum speed, capacity, etc.) that are to be marked on the tool;
- An explanation of any symbols or pictograms marked on the tool;
- The mass of the tool including detachable parts. 

C11 f) Emissions

- 1) a noise emission declaration according to A.1.7.4f of EN 292-2 (determined in accordance with 13.2.7);
- 2) the vibration level, if applicable, according to A.2.2 of EN 292-2 (measured in accordance with 13.3);
- 3) a recommendation for the operator to wear hearing protection. **C11**

C12 g) Connection to water supply

- 1) For tools intended to be connected to a water supply, instructions for the connection to the water supply, the use of the water and the use of attachments to comply with 14.5 in order to avoid affection of the tool by water, the inspection of hoses and other critical parts which could deteriorate and the maximum permitted pressure of the water supply.
- 2) For tools intended to be connected to a water supply, the substance of the following instructions, if applicable:
 - for tools provided with a PRCD: Never use the tool without the PRCD delivered with the tool;
 - for tools provided with an isolating transformer: Never use the tool without the transformer delivered with the tool or of the type as specified in these instructions;
 - Replacement of the plug or the supply cord shall always be carried out by the manufacturer of the tool or his service organisation;
 - Keep water clear off the electrical parts of the tool and away from persons in the working area. **C12**

8 Protection against electric shock

8.1 Tools shall be so constructed and enclosed that there is adequate protection against accidental contact with the live parts and, for class II tools, with metal parts separated from live parts by basic insulation only, even after removal of detachable parts. There shall be, in addition, adequate protection against the risk of contact with basic insulation.

This requirement applies to all positions of the tool, when it is connected and operated as in normal use, even after opening of lids and doors, which can be opened without the aid of a tool and removal of detachable parts.

If a manufacturer instructs the user to remove a part during normal operation or user maintenance, that part is regarded as a detachable part even if a tool has to be used for its removal.

The insulating properties of lacquer, enamel, paper, cotton, oxide film on metal parts, beads, sealing compound and similar coverings shall not be relied upon to give the required degree of protection against accidental contact with live parts.

Enclosures shall have no openings giving access to live parts other than openings necessary for the use and working of the tool, and, for class II tools, to parts separated from live parts by basic insulation only.

C Unless otherwise specified, parts operating at safety extra-low voltage not exceeding 24 V are not considered to be live parts. **C**

Compliance is checked by inspection and, if necessary, by a test with the test finger shown in Figure 1.

In addition, apertures in class II and class I tools, other than those in metal parts connected to an earthing terminal or earthing contact, shall be tested with the test pin shown in Figure 2.

After removal of detachable parts, the test finger and the test pin are applied in every possible position, the test finger being applied without appreciable force and the test pin with a force of 10 N.

Apertures preventing the entry of the test finger are further tested by means of a straight unjointed test finger of the same dimensions, which is applied with a force of 50 N; if this finger enters, the test with the test finger shown in Figure 1 is repeated, except that the force necessary to push the finger through the aperture is exerted. An electrical contact indicator is used to show contact with live parts.

It shall not be possible to touch bare live parts or live parts protected by lacquer, enamel, paper, cotton, oxide film, sealing compound or similar covering only, with the test finger, nor for class II tools, with the test pin.

For class II tools it shall not be possible to touch metal parts separated from live parts by basic insulation only, with the test finger.

It shall not be possible to touch basic insulation with the test finger.

NOTE It is recommended that a lamp be used for contact indication and that the voltage used be not less than 40 V.

During introduction or removing of bulbs, direct contact with live parts of the holder shall be prevented.

8.2 Parts providing protection against electric shock shall have adequate mechanical strength and shall not work loose in normal use.

It shall not be possible to remove the said parts without the aid of a tool.

Compliance is checked by inspection, by manual test and by the tests given in clauses 16 and 19.

8.3 Shafts of operating knobs, handles, levers and the like shall not be live.

Compliance is checked by inspection.

8.4 For tools, other than those of class III, handles or knobs of switch-operating means, if of metal, shall either be adequately covered by insulating material or their accessible parts shall be separated from their shafts of fixing by supplementary insulation.

Compliance is checked by inspection.

8.5 For class II tools, capacitors shall not be connected to accessible metal parts.

Metal casings of capacitors shall be separated from the accessible metal parts by supplementary insulation.

Compliance is checked by inspection and by the tests specified for supplementary insulation.

8.6 Tools shall be so designed that, in normal use, there is no risk of electric shock from charged capacitors.

☐ Capacitors with a rated capacitance not exceeding 0,1 μF are not considered likely to entail a risk of electric shock. In this case the test may be dispensed with. ☐

Compliance is checked by the following test which shall be carried out ten times:

The tool is operated at rated voltage or at the upper limit of the rated voltage range. The tool switch, if any, is then moved to the "OFF" position and the tool is disconnected from the supply by withdrawing the plug.

One second after disconnection, the voltage between the pins of the plug shall not exceed 34 V.

NOTE Care should be taken that the voltage is measured with an instrument which does not appreciably affect the value to be measured.

9 Starting

9.1 Tools shall start under all normal voltage conditions which may occur in use.

Centrifugal and other automatic starting switches shall operate reliably and without contact chattering.

Compliance is checked by starting the tool at no load, three times in succession at a voltage equal to 0,85 times rated voltage or the lower limit of the voltage range, regulating devices, if any, being set as in normal use.

Tools provided with a centrifugal or other automatic starting switch shall be, in addition, started three times in succession at a voltage equal to 1,06 times rated voltage or the upper limit of the voltage range. In all cases the tool shall function correctly.

In accordance with 4.5 the test shall be made at $23\text{ }^{\circ}\text{C} \pm 2\text{ }^{\circ}\text{C}$.

9.2 Overload protection devices shall not operate under normal starting conditions.

Compliance is checked by the test of 9.1.

10 Input and current

10.1 The input of the tool at rated voltage and under normal load shall not deviate from the rated input by more than the values given in Table 1.

Table 1 — Input deviation

Rated input W	Deviation
Up to and including 33,3	+10 W
Over 33,3 up to and including 150	+30%
Over 150 up to and including 300	+45 W
Over 300	+15%

Compliance is checked by measuring the input of the tool operated under normal load at rated voltage or at the mean value of the rated voltage range if the voltage range does not exceed 10% of its mean value.

[C] *For tools marked with a rated voltage range having limits differing by more than 10% of the mean value of the range, the permissible deviations apply for both limits of the range. [C]*

10.2 If the tool is marked with rated current, the current taken by the tool under normal load shall not exceed the rated current by more than 15%.

Compliance is checked by measuring the current taken by the tool operating under normal load conditions, at rated voltage or at the mean value of the rated voltage range, if the voltage range does not exceed 10% of its mean value at rated frequency.

[C] *For tools marked with a rated voltage range having limits differing by more than 10% of the mean value of the range, the permissible deviations apply for both limits of the range. [C]*

11 Heating

11.1 Tools shall not attain excessive temperatures in normal use.

Compliance is checked by determining the temperature rise of the various parts under the following conditions:

11.2 *The tool is operated in still air under normal load or under the torque load necessary to attain rated input or under the loading conditions as specified in Part 2, whichever causes the higher temperature rise, and at a supply voltage equal to 0,94 times, 1,00 times or 1,06 times rated voltage, whichever is the most unfavourable.*

The torque is kept constant at the value recorded when operating at rated voltage, or at the mean of the rated voltage range, under the most unfavourable of the three loading conditions quoted above while the voltage is adjusted to 0,94 or 1,06 times the rated voltage or mean of the rated voltage range.

When applying the torque load necessary to attain rated input, the operating time to be chosen is that specified for normal load.

11.3 *Temperature rises of windings are determined by the resistance method unless the windings are non-uniform or it involves severe complications to make the necessary connections for the resistance measurement. In this case, the measurement is made by thermocouples.*

Such temperature rises are determined by means of fine-wire thermocouples so chosen and positioned that they have the minimum effect on the temperature of the part under test.

In determining the temperature rises of handles, knobs, grips and the like, consideration is given to all parts which are gripped in normal use and, if of insulating material, to those parts in contact with hot metal.

The temperature rise of electrical insulation, other than that of windings, is determined on the surface of the insulation, at places where failure could cause a short-circuit, contact between live parts and accessible metal parts, bridging of insulation or reduction of creepage distances or clearances below the values specified in 27.1.

11.4 *The tool is operated:*

- for the rated operating time for tools for short-time operation;
- on consecutive cycles of operation, until steady conditions are established, for tools for intermittent operation, the "ON" and "OFF" periods being the rated "ON" and "OFF" periods;
- until steady conditions are established for tools for continuous operation.

11.5 *During the test, thermal cut-outs shall not operate. The temperature rises shall not exceed the values shown in Table 2 except as allowed by 11.6.*

Sealing compound, if any, shall not flow out.

Table 2 — Temperature rises

Parts	Temperature rise K
<i>Windings¹⁾, and core laminations in contact therewith, if the winding insulation is:</i>	
- of class A material ²⁾	75 (65)
- of class E material ²⁾	90 (80)
☐ - of class B material ²⁾	95 (85) ☐
- of class F material ²⁾	115
- of class H material ²⁾	140
<i>Ambient of switches and thermostats marked with individual ratings³⁾:</i>	
- without T-marking	30
- with T-marking	T - 25
<i>Pins of appliance inlets:</i>	
- for very hot conditions	130
- for hot conditions	95
- for cold conditions	40
<i>Rubber or polyvinyl chloride insulation of internal and external wiring including power supply cords:</i>	
- without T-marking	50 ⁴⁾
- with T-marking	T - 25 ⁵⁾
<i>Cord sheaths used as supplementary insulation</i>	35
<i>Rubber used for gaskets or other parts, the deterioration of which could affect safety</i>	
- when used as supplementary insulation or as reinforced insulation	40
- in other cases	50
<i>Material used as insulation other than for wires and windings⁶⁾:</i>	
- impregnated or varnished textile, paper or press board	70
- laminates bonded with:	
- melamine-formaldehyde, phenol-formaldehyde or phenol-furfural resins	85 (175)
- urea-formaldehyde resins	65 (150)
- mouldings of:	
- phenol-formaldehyde with cellulose fillers	85 (175)
- phenol-formaldehyde with mineral fillers	100 (200)
- melamine-formaldehyde	75 (150)
- urea-formaldehyde	65 (150)
- polyester with glass-fibre reinforcement	110
- silicone rubber	145
- polytetrafluorethylene	265
- pure mica and tightly sintered ceramic material, when such products are used as supplementary or reinforced insulation	400
- thermoplastic material ⁷⁾	-
<i>Wood, in general⁸⁾</i>	65
<i>Outer surfaces of capacitors:</i>	
☐ - with marking of maximum operating temperature (T)	T - 25 ☐
- without marking of maximum operating temperature	
- small ceramic capacitors for radio and television interference suppression	50
- other capacitors	20
<i>External enclosure, except handles held in normal use</i>	60

Table 2 — Temperature rises (concluded)

<p><i>Handles, knobs, grips and the like which, in normal use, are continuously held:</i></p> <ul style="list-style-type: none"> - of metal - of porcelain or vitreous material - of moulded material, rubber or wood 	<p>30</p> <p>40</p> <p>50</p>
<p><i>Handles, knobs, grips and the like which, in normal use, are held for short periods only (e.g. of switches):</i></p> <ul style="list-style-type: none"> - of metal - of porcelain or vitreous material - of moulded material, rubber or wood 	<p>35</p> <p>45</p> <p>60</p>
<p><i>Parts in contact with oil having a flash-point of t °C</i></p>	<p>t - 50</p>
<p>1) <i>To allow for the fact that the temperature of windings of universal motors, relays, solenoids, etc. measured at points accessible to thermocouples is generally below the average, the figures without parentheses apply when the resistance method is used and those within parentheses apply when thermocouples are used. For windings of vibrator coils and a.c. motors, the figures without parentheses apply in both cases. In case of doubt, the results obtained by means of the resistance method are decisive.</i></p> <p>2) <i>The classification is in accordance with HD 566 S1.</i> <i>Examples of class A material are:</i> - impregnated cotton, silk, artificial silk and paper; - enamels based on oleo- or polyamide resins. <i>Examples of class B material are:</i> - glass fibre, melamine-formaldehyde and phenol-formaldehyde resins. <i>Examples of class E material are:</i> - mouldings with cellulose fillers, cotton fabric laminates and paper laminates, bonded with melamine-formaldehyde, phenol-formaldehyde or phenol-furfural resins; - cross-linked polyester resins, cellulose triacetate films, polyethylene terephthalate films; - varnished polyethylene terephthalate textile bonded with oil-modified alkyd resin varnish; - enamels based on polyvinyl formal, polyurethane or epoxy resins. <i>There is no limit specified for windings insulated with materials other than those of class A, class E, class B or class F, but they shall withstand the test of 11.6.</i> <i>These tests are always made when the temperature rise of windings or core laminations exceeds 75 K and where there are doubts with regard to the classification of winding insulation.</i> <i>For totally enclosed motors the temperature rise limits for class A, class E, and class B may be increased by 5 K.</i> <i>A totally enclosed motor is a motor so constructed that the circulation of the air between the inside and the outside of the case is prevented, but not necessarily sufficiently enclosed to be called airtight.</i></p> <p>3) <i>T signifies the maximum operating temperature.</i> <i>For the purpose of this test, switches and thermal cut-outs marked with individual ratings may be considered as having no marking in this respect, if requested by the tool manufacturer.</i></p> <p>4) <i>This limit applies to cables, cords and wires complying with the relevant CENELEC standards; for others it may be different.</i></p> <p>5) <i>This limit will become applicable as soon as there are CENELEC standards for high temperature cables, cords and wires.</i></p> <p>6) <i>The values in parentheses apply, if the material is used for handles, knobs, grips and the like and is in contact with hot metal.</i></p> <p>7) <i>There is no specific limit for thermoplastic material which shall withstand the tests of 28.1 or 28.2, for which purpose the temperature rise must be determined.</i></p> <p>8) <i>The limit is concerned with the deterioration of wood and it does not take into account deterioration of surface finishes.</i> <i>If these or other materials are used, they shall not be subjected to temperatures in excess of the thermal capabilities as determined by ageing tests made on the materials themselves.</i></p>	

NOTE The values in the table are based on an ambient temperature not normally exceeding 25 °C but occasionally reaching 35 °C.

However, the temperature rise values are based on an ambient temperature of 25 °C.

In determining the temperature rise of the ambient of a switch or thermostat, the temperature rise resulting from the current through the switch or thermostat is not taken into account, provided it does not influence its ambient temperature.

The value of the temperature rise of a copper or aluminium winding is calculated from the formula:

$$\Delta t = \frac{R_2 - R_1}{R_1} (234,5 + t_1) - (t_2 - t_1) \text{ (for copper)}$$

$$\Delta t = \frac{R_2 - R_1}{R_1} (225,0 + t_1) - (t_2 - t_1) \text{ (for electrical conductor grade aluminium)}$$

where:

- Δt is the temperature rise in K
 R_1 is the resistance at the beginning of the test
 R_2 is the resistance at the end of the test
 t_1 is the room temperature at the beginning of the test in °C
 t_2 is the room temperature at the end of the test in °C

At the beginning of the test, the windings are to be at room temperature.

It is recommended that the resistance of windings at the end of the test be determined by taking resistance measurements as soon as possible after switching off, and then at short intervals so that a curve of resistance against time can be plotted for ascertaining the resistance at the instant of switching off.

11.6 *If the temperature rise of a winding exceeds the value specified in 11.5, three additional samples are subjected to the following tests.*

- 1) *The temperature rise of the windings is determined by the test of 11.2.*
- 2) *The samples are then dismantled as far as is possible without damaging any part. Windings and core laminations are kept for 10 days (240 h) in a heating cabinet, the temperature of which is $80\text{ K} \pm 1\text{ K}$ in excess of the temperature rise determined according to item 1).*
- 3) *After this treatment the samples are reassembled and no interturn short circuit shall occur. Interturn short circuits may be detected by means of a winding tester.*
- 4) *Immediately afterwards, the samples shall withstand the tests of clause 15.*
- 5) *The samples are then subjected to a humidity treatment as specified in 14.2. After this treatment, they shall again withstand the tests of clause 15.*
- 6) *Faults which may occur in insulation which did not show an excessive temperature rise during the test of item 1) are ignored and are repaired, if necessary, in order to complete the tests of this subclause. C*

Tools are considered not to comply with the requirements of 11.1, if there are more failures than one sample in one of the tests 3) to 5).

If one sample falls in a test, the tests 1) to 5) are repeated on another set of three samples, all of which shall then comply with the repeated tests.

12 Leakage current

12.1 The leakage current in normal use shall not be excessive.

Compliance is checked by the test of 12.2, carried out immediately after the test of 11.2, the tool being operated under the conditions specified in 11.2, but at a supply voltage equal to 1,06 times rated voltage.

Three-phase appliances which are also suitable for single-phase supply are tested as single-phase appliances with the three sections connected in parallel. The tests are made while the appliance is connected to the supply.

12.2 *The leakage current is measured between any pole of the supply and:*

- *accessible metal parts and metal foil with an area not exceeding 20 cm x 10 cm in contact with accessible surfaces of insulating material, connected together;*
- *metal parts of class II tools, separated from live parts by basic insulation only.*

The measuring circuit is shown in the following figures:

- for single-phase tools having a rated voltage not exceeding 250 V and for three-phase tools to be tested as single-phase tools:
 - if of class II, Figure 3;
 - if other than class II, Figure 4;
- for three-phase tools not suitable for single-phase supply:
 - if of class II, Figure 5;
 - if other than class II, Figure 6.

The measuring circuit has a total resistance of $1\,750\ \Omega \pm 250\ \Omega$ and is shunted by a capacitor such that the time constant of the circuit is $225\ \mu\text{s} \pm 15\ \mu\text{s}$.

The test is made with a.c. unless the tool is for d.c. only, in which case the test is not made.

For single-phase tools having a rated voltage not exceeding 250 V and for three-phase tools to be tested as single-phase tools, the leakage current is measured with the selector switch shown in Figures 3 and 4, in each of the positions 1 and 2.

For three-phase tools not suitable for single-phase supply, the leakage current is measured with the switches a, b and c, shown in Figures 5 and 6 closed; the measurements are repeated with each of the switches a, b and c open in turn, the other two switches being closed. For tools intended to be connected in star connection only the neutral is not connected.

After an operating time as specified in 11.4, the leakage current shall not exceed the following values:

- for class III tools 0,5 mA
- for class I tools 0,75 mA
- for class II tools 0,25 mA
- to metal parts of class II tools separated from live parts by basic insulation only, if the tool is classified according to degree of protection against moisture as:
 - for tool IPX0 5,0 mA
 - other than IPX0 3,5 mA

If the tool incorporates one or more capacitors and is provided with a single-pole switch, the measurements are repeated with the switch in the "OFF" position.

[C] For tools incorporating heating elements the total leakage current shall be either within the limits specified above or within those specified in EN 60335-1, 13.2, whichever is the greater; the two limits shall not be added. **[C]**

NOTE Details of a suitable circuit for measuring leakage currents are given in Annex IA.

[C] The measuring arrangement has an accuracy of within 5% for all frequencies in the range of 20 Hz to 5 000 Hz.

Where leakage currents exceeding 5 mA are measured in a circuit having a total resistance less than $1\,600\ \Omega$, the readings are reduced by 5%.

It is recommended that the tool be supplied through an isolating transformer; otherwise, it must be insulated from earth.

The metal foil has the largest area possible on the surface under test, without exceeding the dimensions specified. If its area is smaller than the surface under test, it is moved so as to test all parts of the surface; the heat dissipation of the appliance must, however, not be affected by the metal foil.

The test with the switch in the "OFF" position is made to verify that capacitors connected behind a single-pole switch do not cause an excessive leakage current.

If the tool incorporates a thermal control which operates during the test of clause 11, the leakage current is measured immediately before the control opens the circuit. **[C]**

13 Environmental requirements

13.1 Dust measurements

If the manufacturer gives information on the dust collection efficiency the effectiveness of the dust collection devices shall be measured in under the following test conditions:

Tests under working conditions, including appropriate rest periods, are carried out in the test cabin (see Figure 11) specified in EN 1093-3 and measurements of dust emission are made in accordance with that standard.

The test period shall be of one hour duration including all running and rest periods.

The orientation within the cabin shall be such that the passage of dust towards the measuring tunnel is not impeded.

The material to be used for the test shall be appropriate for the intended use of the tool and shall be of the following specification.

- a) Wood - beech with a moisture content of $10\% \pm 2\%$.
- b) Chipboard - to ISO 820 General purpose three layer type, with a density of 500 kg/m^3 to 750 kg/m^3 and a moisture content of $8\% \pm 2\%$.
- c) Steel - "T" section or round bar according to ISO 630.

Tests shall be carried out at rated voltage and frequency and at maximum speed setting, if any.

The tool bit/cutter/abrasive etc. to be used shall be as specified by the manufacturer for the material to be worked.

The air velocity of externally connected suction and dust collection systems to be as specified by the manufacturer, or if not specified $20 \text{ ms}^{-1} \pm 2 \text{ ms}^{-1}$. Velocity to be measured in the connecting tube at the point of connection, with the tool connected but not running.

The number of tests carried out shall be sufficient to ensure a statistically reliable result, but in all cases not less than two tests shall be carried out. 

13.2 Noise

13.2.1 Noise reduction

Noise reduction at tools is an integral part of the design process and shall be achieved by particularly applying measures at source to control noise, see for example EN ISO 11688-1. The success of the applied noise reduction measures is assessed on the basis of the actual noise emission values in relation to other machines of the same family with comparable non acoustical technical data.

The major sound sources of tools are given in the relevant Part 2.

13.2.2 Noise emission measurement (general)

Noise emission values like the emission sound pressure level L_{pA} and the sound power level L_{WA} to be quoted in the user instructions as required by 7.13 shall be measured by the test procedure described in 13.2.3 to 13.2.6.

The overall noise emitted is influenced by both the process noise and method of operation. The load conditions for particular tools are therefore specified in the relevant Part 2.

The noise emission values obtained under the measurement conditions described in this standard will not necessarily correspond to the diverse noise levels produced under the operational conditions of practical use. 

NOTE It is not possible to simulate all conditions of practical use. A statement of process noise could therefore

- be misleading and cause faulty assessment of the risk in individual cases,
- discourage the development of more silent machines,
- lead to low repeatability of measurements and thus cause problems when verifying stated noise values,
- make the comparison of the noise emission from different tools difficult.

13.2.3 Instrumentation and preparation of test samples

The instrumentation for the measurement of acoustic values shall be in accordance with EN ISO 3744.

Sound level meters shall comply with the requirements of IEC 60651 Type 1 and shall be used with frequency weighting "A" and response level "S".

Measurements shall be carried out on a new tool, additional to that required by other tests.

All speed setting devices shall be adjusted to the highest figure.

Tools shall be run-in for a period of 5 min before starting test. The supply voltage of mains powered tools is measured at the plug of the cable or cord supplied, not at the plug of any extension cable or cord.

13.2.4 Operating conditions

Tools are tested under the two operating conditions "no load" and "load".

The measurement under "load" shall be carried out during processing of a work piece or under external mechanical load equivalent to normal operation.

If the tool is intended to be used on a bench then it shall be in accordance with the test bench shown in Figure 12.

If the tool is intended to be used with a bench or stand recommended by the manufacturer then it is tested with that bench or stand.

Care shall be taken that the location of the work piece on its support does not adversely affect the result of the test.

Three consecutive tests for no-load or five for load shall be carried out and the resulting sound power level L_{WA} of the test shall be the arithmetic mean, rounded to the nearest decibel, of the three or five tests.

Measurement time shall be 15 s or at least 1 work cycle as defined in the relevant Part 2.

13.2.5 Sound power level determination

The determination of the sound power level shall be carried out according to EN ISO 3744, thus requiring an essentially free field over a reflecting plane as measurement environment.

The microphone positions shall be located in the centre of each lateral surface and the top surface of the measurement cubic surface which envelops the source. For the exact location of the 5 microphone positions and the dimensions of the cubic measurement surface see Figure 13. The machine to be tested shall be so positioned, either placed on the test bench (Figure 12) or with the accompanying bench, that its centre of gravity lies on the line given by the projection of the upper measurement point 5 on the ground floor. The machine shall be so orientated that its front edge is parallel to one of the horizontal side edges of the measurement cube. Any shielding of microphones by the presence of an operator must be avoided.

Measurements are only valid if the difference between the background noise and the tool under test is > 15 dB. **NOTE**

Ⓒ11 The surface sound pressure level, $\bar{L}_{pAf,1m}$, shall be calculated in accordance with the following equation:

$$\bar{L}_{pAf,1m} = 10 \lg \left[\frac{1}{5} \sum_{i=1}^5 10^{0,1L'_{pAi}} \right] - K_{1A} - K_{2A}$$

where

$\bar{L}_{pAf,1m}$ is the A-weighted 1 meter surface sound pressure level, in decibels with respect to 20 μPa

L'_{pAi} is the A-weighted sound pressure level, recorded at the i^{th} microphone position, in decibels with respect to 20 μPa

K_{1A} is the A-weighted background noise correction

NOTE 1 If the difference between the background noise and the tool noise under test is > 15 dB the background noise correction is negligible.

K_{2A} is the A-weighted environmental correction

NOTE 2 The A-weighted environmental correction can be neglected if it is less than or equal to 0,5 dB.

The sound power level, L_{WA} shall be calculated in accordance with the following equation:

$$L_{WA} = \bar{L}_{pAf,1m} + 10 \lg S / S_0$$

where

L_{WA} is the A-weighted sound power level, in decibels with respect to 1 pW

$S_0 = 1 \text{ m}^2$

$S =$ area of the measurement surface according to Figure 13

The area S of the measurement surface according to Figure 13 is given by the formula

$$S = 5 \times (2\text{m} \times 2\text{m}) = 20\text{m}^2$$

13.2.6 Emission sound pressure level determination

The emission sound pressure level shall be determined according to EN ISO 11201. It shall be determined under the same operating conditions as for the determination of the sound power level.

For machines measured under load and run by an operator the microphone shall be located $0,20 \text{ m} \pm 0,02 \text{ m}$ to the side of the centre plane of the operator's head, on a line with the eyes, with its axis parallel to the operator's line of vision, and on that side where the higher value of the A-weighted sound pressure level, L_{pA} is observed. Ⓒ11

Ⓒ11 For machines measured under no load condition and without the operator being present the microphone shall be located at a reference point on the ground plane on which the operator normally stands. If not specified in the machine relevant Part 2 documents this reference point is located 1 m from the centre of the machine on the side where the operator normally stands. The microphone shall be located directly above the reference point at a specified height in the range of $1,55 \text{ m} \pm 0,075 \text{ m}$.

L_{pCpeak} shall be determined at the operator's position if required according to A.1.7.4f of EN 292-2.

13.2.7 Declaration and verification of noise emission values

The declaration of the noise emission values shall be made as a dual number noise emission declaration according to EN ISO 4871.

It shall declare the noise emission values L (e.g. L_{pA} , L_{WA} respectively L_{pCpeak}) and the respective uncertainties K (K_{pA} , K_{WA} respectively K_{pCpeak}) according to A.1.7.4f of EN 292-2 and this standard.

The uncertainties K_{pA} , K_{WA} and K_{pCpeak} are expected to be equal to 3 dB.

The noise declaration shall state that the noise emission values have been obtained according to this noise test code. If this statement is not true, the noise declaration shall indicate clearly what the deviations are from this noise test code and/or from the basic standards.

If undertaken, verification shall be done according to EN ISO 4871 by using the same mounting, installation and operating conditions as those used for the initial determination of noise emission values. Ⓒ11

Ⓒ 13.3 Vibration measurement

13.3.1 The vibration levels for hand-arm vibration shall be measured in accordance with the following test procedure.

It is not intended that the values are used for assessment of human exposure to vibrations. The measurement and assessment of human exposure to hand-transmitted vibration in the workplace is given in ENV 25349.

13.3.2 Vibrations are measured as the acceleration of the handles of the tool under test and shall be expressed as the root-mean-square (r.m.s.) acceleration, a_h , in metres per second squared.

Weighted acceleration values $a_{h,W}$, are obtained by measurement using the weighting filter for hand-arm vibration measurements defined in ENV 28041.

13.3.3 A transducer for measuring acceleration (accelerometer), such as a piezo-electric device, shall be used in conjunction with a suitable preamplifier, ENV 28041 shall be consulted for the specification of the measuring equipment.

The total mass of the accelerometer and its mounting shall be not more than 5 g.

Accelerometers shall be mounted in accordance with ISO 5348.

NOTE The measurement of vibration on handles with resilient covers can be accomplished by using a special adaptor between the hand and the handle. The adaptor may consist of a suitably formed light rigid plate with a suitable mounting arrangement for the accelerometer used. Care should be taken that the mass, size and shape of the adaptor do not significantly influence the signal from the accelerometer in the frequency range of interest.

It should be noted that if the signal for analysis is of short duration, or its magnitude varies substantially with time, a simple analysis cannot be made. In order to obtain r.m.s. values under these circumstances, it is necessary to use an integrating meter or analyser which is equipped with "linear integration" facilities. It is recommended that "linear integration" analysis be adopted as the preferred method. The type of analyser normally used for noise analysis can be used only when the signal is relatively steady with time or is of sufficient duration.

In such circumstances, the time constant chosen shall be appropriate for the signal duration.

13.3.4 Measurements shall be made in the direction of the handle movement. If there is no defined direction then measurements shall be made in all three axes of a basicentric coordinate system. Ⓒ11

☐ Measurements shall be carried out at a point half-way along the length of the handles. If the placing of the switch actuator makes this impossible then the accelerometer shall be placed as close as possible to the hand between the thumb and the index finger.

13.3.5 Measurements shall be carried out on a new tool additional to that required by other tests.

All speed setting devices shall be adjusted to the highest figure.

Tools shall be run-in for a period of 5 minutes before starting the test.

13.3.6 The rated voltage or the upper limit of the rated voltage range and/or frequency shall be maintained during the test at the stated values with a tolerance of $\pm 2\%$.

The supply voltage of mains powered tools is measured at the plug of the cable or cord supplied, not at the plug of any extension cable or cord.

13.3.7 If required by Part 2, the rotational speed of tools etc. is measured with instruments having an accuracy of $\pm 1\%$ of full scale.

13.3.8 Tools are tested under the two operating conditions "no load" and "load".

Three series of seven consecutive tests are carried out using a different operator for each series. The operator shall be skilled in the use of the tool under test.

The measurement under "load" is to be carried out during processing of a workpiece or under external mechanical load equivalent to normal operation.

If the tool is with a bench it is tested with that bench otherwise if it is intended to be used on a bench then it shall be in accordance with the test bench shown in Figure 12.

Care shall be taken that the location of work piece on its support does not adversely affect the results of the tests.

NOTE 1 It should be noted that even small differences in size, shape, material, wear, unbalance etc. of the inserted tool (e.g. sawblade grinding wheel, etc.) can alter the vibration intensity considerably.

NOTE 2 The vibrations of the tool can be influenced by the operator, in particular the grip force has a considerable influence.

13.3.9 The results shall be in weighted acceleration values.

The upper and lower values of each series of seven tests are disregarded and the value stated shall be the average of the remaining tests.

NOTE It should be noted that the measurement methods given can result in different values being measured in different test locations or with different test equipment. ☐

14 Protection against ingress of foreign bodies and moisture resistance

14.1 Tools which are marked with degree of protection against ingress of foreign bodies shall possess that degree of protection under working conditions.

☐ *Compliance with requirements as specified is checked by tests according to EN 60529.*

14.2 Tools with a degree of protection providing a higher degree of severity than IPX0 shall comply with the relevant requirements specified in EN 60529. ☐

Covers and other parts which can be removed without the aid of a tool are removed and tested, if necessary, together with the main part of the tool.

NOTE More detailed test conditions are under consideration.

14.3 Tools shall withstand those effects of humidity which are likely to occur in normal conditions.

Compliance is checked by the humidity treatment described in this subclause, immediately followed by tests as given in clause 15.

Covers and other parts which can be removed without the aid of a tool are removed and subjected, if necessary, to the humidity treatment together with the main part.

The humidity treatment is carried out in a humidity cabinet containing air with a relative humidity maintained between 91% and 95%. The temperature of the air, at all places where samples can be located, shall be maintained within ± 1 K of any convenient value t between 20 °C and 30 °C.

Before being placed in the humidity cabinet the sample is brought to a temperature between t °C and $(t \pm 4)$ °C for 24 h.

The sample is kept in the humidity cabinet for

- *2 days (48 h) for tools with degree of protection IPX0;*
- *7 days (168 h) for all other tools.*

Ⓒ *In most cases the sample can be brought to the temperature specified by keeping it at this temperature for at least 4 h before the humidity treatment.*

A relative humidity between 91% and 95% can be obtained by placing a saturated solution of sodium sulphate (Na_2SO_4) or Potassium nitrate (KNO_3) in water, in the humidity cabinet, the said solution having a sufficiently large contact surface with the air.

In order to achieve the specified conditions within the cabinet it is necessary that constant circulation of the air within the cabinet is ensured and that, in general, a thermally insulated cabinet be used. Ⓒ

14.4 Tools subject to spillage of liquid in normal use shall be so constructed that the said spillage does not affect their electrical insulation.

Compliance is checked by the following test:

Tools provided with an appliance inlet are fitted with an appropriate connector and flexible cable or cord.

Other tools are fitted with the lightest permissible type of cable or cord of the smallest cross-sectional area specified in 23.4.

The liquid container of the tool is filled to the top with water and a further quantity, equal to 15% of the capacity of the container, is poured in steadily over a period of 1 min.

Immediately following this treatment the tool shall withstand an electric strength test as specified in 15.3.

Inspection shall show that no appreciable quantity of water has entered the appliance and that there are no traces of water on insulating parts for which minimum creepage distances are specified in 27.1.

The test can be carried out on a separate sample.

Ⓒ₁₂ 14.5 Tools, except those of class III, intended to be connected to a water supply shall be constructed so that the electrical insulation of the tool is not affected by water during recommended operation.

Compliance is checked by the following test.

The tool is connected to a water supply and operated at 1,06 times rated voltage for 5 min in the most unfavourable position in accordance with the manufacturer's instructions.

Throughout the test the leakage current between live parts and the enclosure as specified in 12.2 is monitored. The leakage current *shall not exceed the value specified in 12.2.*

Immediately after this treatment inspection shall show that water has not entered the tool to any appreciable extent and that there is no trace of water on insulation for which creepage distances are specified in 27.1. Ⓒ₁₂

15 Insulation resistance and electric strength

15.1 Tools shall possess adequate insulation resistance and electric strength.

Compliance is checked by tests as specified in 15.2 and 15.3, which are carried out on the cold tool not connected to the supply, immediately following the test according to 14.3 in the humidity cabinet or in the room in which the sample was brought to the prescribed temperature, and after reassembly of those parts which may have been removed.

15.2 *The insulation resistance is measured with a d.c. voltage of approximately 500 V applied, the measurement being made 1 min after application of the voltage, heating elements, if any, being disconnected.*

The insulation resistance shall be not less than that shown in Table 3.

Table 3 — Insulation resistance

<i>Insulation to be tested</i>	<i>Insulation resistance MΩ</i>
<i>Between live parts and the body:</i> <i>- for basic insulation</i> <i>- for reinforced insulation</i>	 2 7
<i>Between live parts and metal parts of class II tools which are separated from live parts by basic insulation only</i>	2
<i>Between metal parts of class II tools which are separated from live parts by basic insulation only and the body</i>	5

15.3 *Immediately after the test of 15.2, the insulation is subjected for 1 min to a voltage of substantially sine-wave form, having a frequency of 50 Hz or 60 Hz. The value of the test voltage and the points of application are shown in Table 4.*

Table 4 — Test voltages

Points of application of test voltage	Test voltage V		
	class III tools	class II tools	class I tools
1. Between live parts and parts of the body that are separated from live parts by:			
- basic insulation only	500	—	1 250
- reinforced insulation	—	3 750	3 750
2. Between live parts of different polarity	500	1 250	1 250
3. For parts with double insulation, between metal parts separated from live parts by basic insulation only and:			
- live parts	—	1 250	1 250
- the body	—	2 500	2 500
4. Between metal enclosures or covers lined with insulating material and metal foil in contact with the inner surface of the lining, if the distance between live parts and these metal enclosures or covers, measured through the lining, is less than the appropriate clearance as specified in 27.1.	—	2 500	1 250
5. Between metal foil in contact with handles, knobs, grips and the like and their shafts, if these shafts can be live in the event of an insulation fault	—	2 500	2 500
6. Between the body and either metal foil wrapped around the supply flexible cable or cord inside inlet bushings, cord guards, cord anchorages and the like, or a metal rod of the same diameter as the flexible cable or cord, inserted in its place	—	2 500	1 250
7. Between the point where a winding and a capacitor are connected together, if a resonance voltage U occurs between this point and any terminal for external conductors, and:			
- the body	—	—	$2 U + 1 000$
- metal parts separated from live parts by basic insulation only	—	$2 U + 1 000$	—
Should separate testing of the basic and supplementary insulation not be possible without disassembling or modifying the tool, a separate sample is used which is subjected to the test of 14.3 after disassembly or modification.			
The test between live parts of different polarity is only made where the necessary disconnections can be made without damaging the tool.			
The test is not made between the contacts of switches of micro-gap construction, motor-starting switches, relays, thermostats, thermal cut-outs and the like, or on the insulation of capacitors connected between live parts of different polarity.			

Initially, not more than half the prescribed voltage is applied, then it is raised rapidly to the full value.

No flashover or breakdown shall occur during the test.

☐ Care is taken that the metal foil is so placed that no flashover occurs at its edges.

For class II tools incorporating both reinforced insulation and double insulation, care is taken that the voltage applied to the reinforced insulation does not overstress the basic insulation or the supplementary insulation.

When testing insulating barriers, the metal foil may be pressed against the insulation by means of a sandbag of such a size that the pressure is about 5 kPa (0,5 N/cm²). The test may be limited to places where the insulation is likely to be weak, for example where there are sharp edges under the insulation.

If practicable, insulating linings are tested separately.

The high-voltage transformer used for the test must be so designed that, when the output terminals are short-circuited after the output voltage has been adjusted to the appropriate test voltage, the output current is at least 200 mA.

The overcurrent relay must not trip when the output current is less than 100 mA. ☐

16 Endurance

16.1 Tools shall be so constructed that, in extended normal use, there will be no electrical or mechanical failure that might impair compliance with this standard. The insulation shall not be damaged and contacts and connections shall not work loose as a result of heating, vibration, etc.

Moreover, overload protection devices shall not operate under normal running conditions.

Compliance is checked by the test of 16.2 and, for tools provided with a centrifugal or other starting switch, also by the test of 16.3.

Immediately after these tests, the tool shall withstand an electric strength test as specified in 15.3, the test voltages being however, reduced to 75% of the specified values. Connections shall not have worked loose and there shall be no deterioration impairing safety in normal use.

16.2 The tool is operated intermittently with no load for 24 h of operation at a voltage equal to 1,1 times rated voltage and then for 24 h at a supply voltage equal to 0,9 times rated voltage.

Each cycle of operation comprises an "ON" period of 100 s and an "OFF" period of 20 s, the "OFF" period being included in the specified operating time.

The operating period for tools for short-time or intermittent operation is equal to that operating time, if this is limited by the construction of the tool; otherwise, it is in accordance with the prescriptions given in Part 2, or with the marking, whichever is the more unfavourable.

During the test, if different positions of normal use are possible, the test is carried out in the most unfavourable position within the manufacturer's recommended positions of use.

If the temperature rise of any part of the tool exceeds the temperature rise determined during the test of 11.1, forced cooling or rest periods are applied, the rest periods being excluded from the specified operating time.

During these tests, overload protection devices shall not operate.

NOTE 1 The tool may be switched on and off by means of a switch other than that incorporated in the tool.

NOTE 2 During this test, replacement of the carbon brushes is allowed and the tool is oiled and greased as in normal use.

16.3 Tools provided with a centrifugal or other automatic starting switch are started 10000 times under normal load and at a voltage equal to 0,9 times rated voltage, the operating cycle being that specified in 16.2.

17 Abnormal operation

17.1 Tools shall be so designed that the risk of fire, mechanical damage or electric shock as a result of abnormal or careless operation is obviated as far as is practicable.

Compliance is checked by the following test, cutting tools like sawblades, grinding wheels, etc. being removed.

- *Tools incorporating commutator motor are operated at a voltage equal to 1,3 times rated voltage or the upper limit of the voltage range for 1 min at no load.*

Following this test windings and connections shall not have worked loose and the tool shall be fit for further use.

- *The following categories of tools incorporating induction motors:*

- 1) *with a starting torque less than the full-load torque; or*
- 2) *started by hand; or*

- 3) *provided with moving parts which are liable to be jammed, or where the moving parts can be stopped by hand, the motor remaining switched on during this operation, are connected, starting from cold, to their rated voltage or the upper limit of their rated voltage range with the moving parts locked:*
- *for 30 s for tools that are operated by hand during use;*
 - *for 5 min for tools that are attended during use.*
- *Tools incorporating three-phase motors are operated, starting from cold, for 30 s, if kept switched on by hand or continuously loaded by hand, or otherwise for 5 min, with one phase disconnected and under the torque producing normal load.*

At the end of the test period specified, or at the instant of operation of fuses, thermal cut-outs, motor protection devices and the like, the temperature of the windings shall not exceed the value shown in Table 5.

Table 5 — Maximum winding temperature

Protection of windings	Limiting temperature °C				
	Class A	Class E	Class B	Class F	Class H
Protection by impedance	150	165	175	190	210
Protection by protection devices which operate during the test	200	215	225	240	260

NOTE Fuses, thermal cut-outs, overcurrent releases or the like, incorporated in the tool, are considered to provide adequate protection against the risk of fire.

17.2 Tools incorporating electronic control devices shall be so designed that, in the event of a failure in the electronic equipment, it shall not result in a hazard.

Compliance is checked by operating the tool for 1 min, at rated voltage or at the mean value of the rated voltage range, at no load, with the electronic control device short-circuited.

The test is then repeated with the electronic control device open-circuited.

Following these tests the tool shall show no damage within the meaning of this standard.

Ⓒ *If the tool incorporates a device for limiting speed and should the electronic control device fail to operate, the tool is considered to have withstood the test when the said speed limiting device operates during the test. Ⓒ*

17.3 Switches or other devices for motor reversal shall withstand stresses occurring when the sense of rotation is reversed under running conditions where such a reversal is possible in normal use.

Compliance is checked by the following test:

The tool is operated at a voltage equal to rated voltage or at the upper limit of the rated voltage range, at no load, the device for reversing the sense of rotation being in such a position that the rotor rotates in one direction at full speed.

The direction of rotation is then reversed, without the device resting in an intermediate "OFF" position.

This operation sequence is performed 25 times.

During the test, no electrical or mechanical failure of the device and no burning or undue pitting of the contacts shall occur.

After the test, the tool shall show no damage within the meaning of this standard.

18 Stability and mechanical hazards

18.1 Moving and other dangerous parts shall as far as is compatible with the use and mode of function of the tool be so arranged or enclosed that, in normal use, adequate protection against injury is provided.

Protective enclosures, covers, guards and the like shall possess adequate mechanical strength for their intended purpose.

Fixed guards shall be used when frequent access is not required and removal of this type of guard shall only be possible with the aid of a tool. Where more frequent access is required, movable or removable guards shall be provided to enclose the dangerous parts of the tool.

When used as protection of the working element the guard shall have an easily accessible means of accurate adjustment with the objective of minimizing access to the dangerous parts.

The use and adjustment of a guard shall not create other dangers, e.g. by reducing or obstructing the operator's view, by transferring heat or causing other predictable hazards.

All working elements, including special features or attachments intended as part of the tool shall be secured so that they cannot create dangers during normal use by moving, or being released, out of the normal working constraints of the tool.

NOTE Such dangers might be caused by vibration, reversal of motion and electric braking.

Compliance is checked by inspection, by tests according to clause 19 and by means of a test using the standard test finger shown in Figure 1. It shall not be possible to touch dangerous moving parts with this finger.

☐ It shall not be possible to touch dangerous moving parts through dust collection openings after removing any detachable parts of the dust collection system.

Compliance is checked by means of a test using the test finger shown in Figure 1. ☐

18.2 Tools intended to be used without fixing to the floor or to a table shall have adequate stability.

Compliance is checked by the following test, tools provided with an appliance inlet being fitted with an appropriate connector and flexible cable or cord.

The tool is placed with the motor switched off in any normal position of use on a plane inclined at an angle of 10° to the horizontal, the cable or cord resting on the inclined plane in the most unfavourable position. If, however, the tool is such that, were it to be tilted through an angle of 10° when standing on a horizontal plane, a part of it not normally in contact with the supporting surface would touch the horizontal plane, the tool is placed on a horizontal support and tilted in the most unfavourable direction through an angle of 10°.

Tools provided with doors are tested with the doors open or closed, whichever is the more unfavourable.

Tools intended to be filled with liquid by the user in normal use are tested empty or filled with the most unfavourable quantity of water or the recommended liquid, up to the rated capacity.

The tool shall not overturn.

18.3 Tools shall have adequate stability when used under the most onerous conditions of normal use following the manufacturer's instruction.

Compliance is checked by the tests of the relevant Part 2.

18.4 Accessible parts likely to be touched during normal use shall be free from sharp edges, burrs, flashes and the like.

Compliance is checked by inspection.

19 Mechanical strength

19.1 Tools shall possess adequate mechanical strength and shall be so constructed that they withstand such rough handling as is to be expected in normal use.

Compliance is checked by the test specified in 19.2.

Following this test the tool shall withstand an electric strength test as specified in 15.3 and shall show no damage within the meaning of this standard, in particular, live parts shall not have become accessible.

☐ *Damage to the finish, small dents which do not reduce creepage distances or clearances below the values specified in 27.1, or small chips which do not adversely affect protection against shock or moisture may be disregarded.*

The function of mechanical safety devices shall not be impaired thereby.

Cracks not visible to the naked eye and surface cracks in fibre-reinforced moldings and the like are disregarded.

Where a decorative cover is backed by an inner cover, a fracture of the decorative cover is disregarded when the inner cover withstands the test after removal of the decorative cover.

19.2 Blows are applied to the tool by means of the spring-operated impact test apparatus described in EN 60068-2-75 (see Figure 7). **☐**

The spring is so adjusted that it causes the hammer to strike with an impact energy as shown in the following table, the spring compression being as shown in Table 6.

Table 6 — Impact energies

Part to be tested	Impact energy Nm	Compression mm
<i>Brush caps</i>	<i>0,5 ± 0,05</i>	<i>20,0</i>
<i>Other parts</i>	<i>1,0 ± 0,05</i>	<i>28,3</i>

The release mechanism springs are so adjusted that they exert just sufficient pressure to keep the release jaws in the engaged position.

The apparatus is cocked by pulling the cocking knob until the release jaws engage with the groove in the hammer shaft.

The blows are applied by pushing the release cone against the sample in a direction perpendicular to the surface of the sample at the point to be tested.

The pressure is slowly increased so that the cone moves back until it is in contact with the release bars, which then move to operate the release mechanism and allow the hammer to strike.

The sample as a whole is rigidly supported and three blows are applied to every point of the enclosure which is likely to be weak.

Where necessary, blows are also applied to protective devices, handles, levers, knobs and the like.

19.3 Brush-holders and their caps shall have adequate mechanical strength.

Compliance is checked by inspection and, in case of doubt, by removing and replacing the brushes ten times, the torque applied when tightening the cap being as shown in Table 7.

Table 7 — Test torques

Blade width of test screwdriver mm	Torque Nm
<i>Up to and including 2,8</i>	<i>0,4</i>
<i>over 2,8 up to and including 3,0</i>	<i>0,5</i>
<i>over 3,0 up to and including 4,1</i>	<i>0,6</i>
<i>over 4,1 up to and including 4,7</i>	<i>0,9</i>
<i>over 4,7 up to and including 5,3</i>	<i>1,0</i>
<i>over 5,3 up to and including 6,0</i>	<i>1,25</i>

☐ The blade width of the test screwdriver must be as large as possible but must not exceed the length of the recess in the cap. If, however, the thread diameter is smaller than the length of the recess, the blade width must not exceed this said diameter. The torque must not be applied in jerks. ☐

After this test, the brush-holder shall show no damage impairing its further use, the thread, if any, shall not be damaged and the cap shall show no cracks.

20 Construction

20.1 Tools shall be of class I, class II or class III construction only.

Compliance is checked by inspection.

20.2 Tools which can be adjusted to suit different voltages, or to different speeds, shall be so constructed that accidental changing of the setting is unlikely to occur, if such a change might result in a hazard.

Compliance is checked by inspection and by manual test.

20.3 Tools shall be so constructed that accidental changing of the setting of control devices is unlikely to occur.

Compliance is checked by manual test.

20.4 It shall not be possible to remove parts which ensure the required degree of protection against moisture without the aid of a tool.

Compliance is checked by manual test.

20.5 If handles, knobs and the like are used to indicate the position of switches or similar components, it shall not be possible to fix them in a wrong position if this might result in a hazard.

Compliance is checked by inspection and by manual test.

20.6 Components which may require replacement, such as switches and capacitors, shall be suitably fitted so as to facilitate their replacement.

Compliance is checked by inspection and, if necessary, by manual test.

☐ This requirement is considered to be met if the components form part of an assembly which is itself suitably fitted.

Fixing by means of soldered or crimped connections is allowed only for small resistors, capacitors, inductors and the like, if these components can be suitably fixed by their connecting means. Fixing by means of rivets is not allowed.

Fixing by clamping and fixing by means of suitably shaped casing, such as the provision of a recess which holds the component in position, is allowed. ☐

20.7 Replacement of a flexible cable or cord requiring the displacement of a switch which acts also as a terminal for external conductors shall be possible without subjecting internal wiring to undue stress; after repositioning of the switch and before reassembling the tool, it shall be possible to verify whether the internal wiring is correctly positioned.

Compliance is checked by inspection and by manual test.

☐ 20.8 Wood, cotton, silk, ordinary paper and similar fibrous or hygroscopic material shall not be used as insulation, unless impregnated or chemically rendered non-fibrous, for example: if the interstices between the fibres of the material are substantially filled with a suitable insulant.

Asbestos shall not be used under any circumstances. ☐

Driving belts shall not be relied upon to ensure electrical insulation.

Compliance is checked by inspection.

20.9 Reinforced insulation shall only be used when it is manifestly impracticable to provide separate basic insulation and supplementary insulation.

☐ Appliance inlets, switches, brush holders and armature coils on shafts are examples where reinforced insulation may be used. ☐

Compliance is checked by inspection.

20.10 Insulating barriers of class II tools and parts of class II tools which serve as supplementary insulation or reinforced insulation, and which might be omitted during reassembly after routine servicing, shall either

- be fixed in such a way that they cannot be removed without being seriously damaged; or
- be so designed that they cannot be replaced in an incorrect position and that, if they are omitted, the tool is rendered inoperable or manifestly incomplete.

Compliance is checked by inspection and by manual test.

☐ *Routine servicing includes replacement of power supply cords, switches and the like.*

This requirement is met if the barrier is so fixed that it can only be removed by breaking or cutting.

Fixing by means of an adhesive is allowed only if the mechanical strength of the joint is equal to that of the barrier.

An adequate internal lining of insulating material or an adequate internal insulating coating on metal enclosures is considered to be an insulating barrier provided that the coating cannot easily be removed by scraping.

For class II tools, a sleeve on an insulated internal conductor, other than the core of an external flexible cable or cord, is considered to be an adequate insulating barrier, if it can only be removed by breaking or cutting, or if it is clamped at both ends.

Ordinary lacquering on the inside of metal enclosures, varnished cambric, flexible resin-bonded paper or the like are not considered to be insulating barriers. ☐

20.11 Any assembly gap with a width greater than 0,3 mm in supplementary insulation shall not be coincidental with any such gap in basic insulation, neither shall any such gap in reinforced insulation give straight access to live parts.

Compliance is checked by inspection and measurement.

20.12 Class I tools shall be so constructed that, should any wire, screw, nut, washer, spring or similar part become loose or fall out of position, it cannot become so disposed that accessible metal is made live.

Class II tools shall be so constructed that, should any such part become loose or fall out of position, it cannot become so disposed that creepage distances or clearances over supplementary insulation or reinforced insulation are reduced to less than 50% of the values specified in 27.1.

Class II tools, other than those of the all-insulated type, shall be provided with insulating barriers between accessible metal and motor parts and other live parts.

Compliance is checked by inspection, by measurement and by manual test.

☐ *For class I tools, this requirement can be met by the provision of barriers, or by fixing the parts adequately and by providing sufficiently large creepage distances and clearances. ☐*

Ⓒ It is not to be expected that two independent parts will become loose or fall out of position at the same time.

For electrical connections, spring washers are not considered to be adequate for preventing the loosening of the parts.

Wires are considered as likely to become free from terminals or soldered connections, unless they are held in place near to the terminal or termination, independent of the terminal connection or solder.

Short rigid wires are not regarded as liable to come away from a terminal, if they remain in position when the terminal screw is loosened. Ⓒ

20.13 Supplementary insulation and reinforced insulation shall be so designed or protected that they are not likely to be impaired by deposition of dirt, or by dust resulting from wear of parts within the tool, to such an extent that creepage distances and clearances are reduced below the values specified in 27.1.

Parts of natural or synthetic rubber used as supplementary insulation in class II tools shall be resistant to ageing and be so arranged and dimensioned that creepage distances and clearances are not reduced below the values specified in 27.1, even if cracks occur.

Compliance is checked by inspection, by measurement and, for rubber, by the following test.

Parts of rubber are aged in an atmosphere of oxygen under pressure. The samples are suspended freely in an oxygen bomb, the effective capacity of the bomb being at least ten times the volume of the samples. The bomb is filled with commercial oxygen not less than 97% pure, to a pressure of $2,1 \text{ MPa} \pm 0,07 \text{ MPa}$.

The samples are kept in the bomb at a temperature of $70 \text{ }^\circ\text{C} \pm 1 \text{ }^\circ\text{C}$, for 4 days (96 h). Immediately afterwards, they are taken out of the bomb and left at room temperature, avoiding direct daylight, for at least 16 h.

After this test, the samples are examined and shall show no cracks visible to the naked eye.

In case of doubt with regard to materials other than rubber, special tests may be made.

Ⓒ **WARNING:** The use of the oxygen bomb presents some danger unless handled with care. All precautions should be taken to avoid the risk of explosion due to sudden oxidation. Ⓒ

20.14 Tools shall be so constructed that insulation of internal wiring, windings, commutators, slip rings and the like, and insulation in general, are not exposed to oil, grease or similar substances, unless the construction necessitates that insulation be exposed to oil or grease, as in gears and the like, in which case the oil or grease shall have adequate insulating properties.

Compliance is checked by inspection.

Ⓒ Exposure of internal wiring, windings, commutators, slip rings and the like, and of insulation in general, to oil, grease and similar substances is allowed, provided these substances have no deleterious effect on such parts.

The insulating properties of the oil or grease will already have been checked by the test of 15.3. Ⓒ

20.15 It shall not be possible to gain access to brushes without the aid of a tool.

Screw-type brush-caps shall be so designed that, when tightening, two surfaces are clamped together.

Brush-holders which retain the brushes in position by means of a locking device shall be so designed that the locking does not depend upon the brush-spring tension, if loosening of the locking device might make accessible metal parts live.

Screw-type brush-caps which are accessible from the outside of the tool shall be of insulating material or be covered with insulating material of adequate mechanical and electrical strength; they shall not project beyond the surrounding surface of the tool.

Compliance is checked by inspection and by manual test, the properties of the insulating material being verified:

- by the tests of 19.1 and 19.3 for screw-type brush-caps which are accessible from the outside of the tool;
- by the tests specified for supplementary insulation for class I tools and class III tools;
- by the tests specified for reinforced insulation for class II tools.

20.16 Radio and television interference suppressors shall be so fitted that they are adequately protected by the tool against mechanical damage.

Compliance is checked by inspection and by the test of 19.1.

☐ *The suppressors may be either within the enclosure of the tool or in a strong casing firmly fixed to the tool.*

Care should be taken, when designing the tool, to allow adequate space for fitting these suppressors. **☐**

20.17 Tools shall be fitted with a mains switch.

20.18 Switches shall be so located that accidental operation is unlikely to occur.

Compliance is checked by inspection.

20.19 Tools shall be fitted with a switch or control device which can be easily actuated, entailing no danger, from the operator's place to stop the machine.

Compliance is checked by inspection.

20.20 After voltage recovery, following an interruption of the supply, the reactivation of the tool shall not give rise to danger.

☐ 20.21 Tools, as identified in the relevant Parts 2 or where in normal use a considerable amount of dust which is hazardous to health is expected to be produced, shall have either:

- a) integral dust collection devices; or
- b) devices which allow the connection of external dust collection equipment.

If the solutions a) or b) are not reasonably practicable, the tool shall be designed in such a way that the dust shall not be thrown in the direction of the operator.

Compliance is checked by inspection. **☐**

C12 20.22 Tools intended to be connected to a water supply shall either:

- be of class III;
- or be of class II for use in combination with an isolating transformer. The tool shall be provided with a plug in accordance with EN 60309-2, with the earthing contact position 12 h, but the earth pin of the plug not connected;
- or be of class II or of class I but with class II construction and provided with a PRCD. The PRCD shall have a sensitivity of 30 mA or less. The PRCD shall not be provided with a switch contact for the protective conductor, which opens, when the PRCD trips due to a residual current. The PRCD may be incorporated either:
 - in the tool; or
 - in the cord; or
 - in the plug; or
 - in a separate control box with one or more socket outlets in accordance with EN 60309-2 with the earthing contact position 1 h.

PRCDs incorporated in the cord, in the plug or in a separate control box shall have a degree of protection against the ingress of water of at least IPX4. **C12**

21 Internal wiring

21.1 Internal wiring shall be either so rigid and so fixed or so insulated that, in normal use, creepage distances and clearances cannot be reduced below the values specified in 27.1.

Insulation, if any, shall be such that it cannot be damaged in normal use.

Compliance is checked by inspection, by measurement and by manual test.

C *In case of doubt with regard to the insulation, an electric strength test shall be carried out between the conductor and metal foil wrapped around the conductor insulation, a test voltage of 2000 V being applied for 15 min.*

C1

21.2 Internal wiring and electrical connections between various parts of the tool shall be adequately protected or enclosed.

21.3 Wireways shall be smooth and free from sharp edges, burrs, flashes and the like which might cause dangerous abrasion of the wiring insulation.

Holes in metal, through which insulated wires pass, shall be provided with bushings or shall have smooth well-rounded edges.

Adequate means shall be provided to prevent wiring from coming into contact with moving parts.

21.4 In the case of class II tools adequate means shall be provided to prevent direct contact occurring between the insulation of wiring with basic insulation only and accessible metal parts.

☐ Insulating sleeves may be used to prevent such contact, provided that the sleeves withstand the tests specified for supplementary insulation and that the conductors or sleeves are not likely to be mislaid or lost during routine servicing and repair. ☐

21.5 Conductors identified by the colour combination green/yellow shall not be connected to terminals other than earthing terminals.

Compliance with requirements as given in 21.2 to 21.5 is checked by inspection.

21.6 Wiring between different parts of a tool which can move in normal use or during user servicing relative to each other and its electrical connections, including those providing earthing continuity shall not be exposed to undue stress.

If flexible metallic tubes are used for the protection of conductors between these parts, such tubes shall not cause damage to the insulation of the conductors contained therein.

Open-coil springs shall not be used to protect conductors.

If a coiled spring, the turns of which touch one another, is used for this purpose, an adequate insulating lining shall be provided in addition to the insulation of the conductors.

Compliance is checked by inspection and by the following test:

If flexing occurs in normal use the appliance is placed in the normal position of use and is operated at rated voltage or at the upper limit of the rated voltage range, in accordance with conditions of adequate heat discharge and/or under normal load.

The movable part is moved backwards and forwards, so that the conductor is flexed through the largest angle permitted by the design.

The number of flexings for conductors flexed in normal use is 10 000 and the rate of flexing 30 per min.

After the test, the tool shall show no damage within the meaning of this standard and no damage impairing its further use. In particular, the wiring and its connections shall withstand an electric strength test as specified in 15.3, the test voltage being, however, reduced to 1 000 V and applied between live parts and other metal parts only.

☐ A flexing is one movement either backwards or forwards.

The sheath of a flexible cable or cord complying with HD 21 or HD 22 is regarded as an adequate insulating lining. ☐

21.7 Where wiring is moved under normal operating conditions, precautions shall be taken to ensure that a minimum distance of 25 mm is kept permanently between moving parts and the wiring.

Where this is not possible means shall be provided to prevent contact between the wiring and the moving parts.

Compliance is checked by inspection.

21.8 Aluminium wires shall not be used for internal wiring.

NOTE Windings of a motor are not considered to be internal wiring.

22 Components

☐ 22.1 Components shall comply with the safety requirements specified in the relevant CENELEC standards as far as they reasonably apply. ☐

If components are marked with their operating characteristics, the conditions under which they are used in the tool shall be in accordance with these markings (see note 3 of Table 2).

Capacitors connected in series with a motor winding shall be marked with their rated voltage, in volts, and their rated capacitance, in microfarads.

☐ *Text deleted* ☐

The testing of components which have to comply with other standards is, in general, carried out separately, according to the relevant standard as follows:

It is checked that the marking of components marked with individual ratings suits the conditions which may occur in the tool. The component is then tested in accordance with its marking, the number of samples being that required by the relevant standard. Components not marked with individual ratings are tested under the conditions occurring in the tool, the number of samples being in general, that required by the relevant standard.

For capacitors connected in series with a motor winding, it is verified that, when the tool is operated at a voltage equal to 1,1 times rated voltage and under minimum load, the voltage across the capacitor is not greater than 1,1 times the rated voltage of the capacitor.

☐

Components incorporated in the tool are subjected to all the tests of this standard as part of the tool.

NOTE Compliance with the CENELEC standard for the relevant component does not necessarily ensure compliance with the requirements of this standard. ☐

22.2 Mains switches shall have a contact separation of at least 3 mm. They shall possess adequate breaking capacity and shall be switches designed for frequent operation.

Compliance is checked by inspection and by the following tests:

Mains switches are tested together with the tool, at rated voltage or at the upper limit of the rated voltage range of the tool.

The motor(s) is(are) then stalled and the switch operated 50 times, each "ON" period lasting no longer than 0,5 s and each "OFF" period lasting at least 10 s.

Where, in normal use, an electronic control device switches off the current before opening the main contacts, the number of operations is reduced to five, with the electronic control device short-circuited.

During this test no sustained arcing, or undue burning, pitting or welding of contacts shall occur and there shall be no electrical or mechanical failure.

☐ *Switches marked with individual ratings are tested in accordance with EN 61058-1.* ☐

For series and universal motors, switches not marked with individual ratings are also tested under the conditions occurring in the tool with the current I_M corresponding to the rated input of the tool.

Moreover the current to be used in the breaking capacity test shall be six times I_M when closing and three times I_M when opening.

The current used in the normal operation test shall be five times I_M when closing and I_M when opening.

☐ *The power factor is unity p.f. in all cases. The number of samples is that given in EN 61058-1.* ☐

For other motors, switches not marked with individual ratings are tested under the conditions occurring in the tool as follows:

The currents and their corresponding power factors during switching-on operations in accordance with conditions of adequate heat discharge and /or under normal load of the tool are measured.

☐ *The switch may then be tested separately, according to EN 61058-1.* ☐

The switching-on current and the corresponding power factor so measured being used for the breaking capacity test specified in clause 15 of that publication and the current and power factor measured under conditions of adequate heat discharge and/or normal load being used for the normal operation test specified in clause 16 of that publication.

22.3 Mains switches shall not be fitted in the flexible cables or cords.

Compliance is checked by inspection.

22.4 Overload protection devices shall be of the non-self-resetting type.

Compliance is checked by inspection.

☐ 22.5 Plugs and appliance inlets for safety extra-low voltage circuits or for frequencies other than 50 Hz or 60 Hz and plugs and connections on flexible cables and cords used for an intermediate connection between different parts of a tool shall not be interchangeable with plugs and socket-outlets complying with IEC 60083, nor with connectors and appliance inlets complying with EN 60320-1, where direct supply of these parts could cause danger to persons or surroundings, or damage to the tool. ☐

Compliance is checked by inspection and by manual test.

22.6 Capacitors shall not be connected between the contacts of thermal cut-outs.

Compliance is checked by inspection.

22.7 Components for basic radio and television interference suppression shall not be incorporated in the plugs.

22.8 Inductors for radio and television interference suppression inserted in the earthing circuit shall not attain excessive temperatures in normal use and shall withstand short-circuit currents which may occur in the event of an insulation fault.

Compliance is checked by the following tests:

The inductor is loaded for 1 h with a current of 19 A, after which the temperature rise of the inductor and of parts in its vicinity shall not exceed 1,7 times the limits shown in Table 2.

The inductor is then connected to a 250 V a.c. supply source protected by a 10 A fuse and the tool is short-circuited to earth.

After the test, the inductor shall show no damage impairing its further use.

☐ *The current of 19 A corresponds with the smaller test current of a 10 A fuse-link.*

22.9 Appliance couplers shall comply with EN 60320-1. ☐

23 Supply connection and external flexible cables and cords

23.1 Tools shall be provided with either a power supply cord with type X or type M attachment or an appliance inlet.

It shall not be easily possible to replace the power supply cord for type M attachment by a cord for type X attachment.

If an appliance inlet is used, it shall be so placed that the connector can be inserted without difficulty.

It shall be so located or enclosed that no live parts or none of the pins will be exposed to accidental contact during insertion or removal of a connector.

☐ *Compliance is checked by inspection and by means of the test finger shown in Figure 1, or, for appliance inlets, by means of the appropriate gauges specified in EN 60320-1. ☐*

☐ 23.2 Non-detachable flexible cables and cords shall not be lighter than: ordinary rubber-sheathed flexible cords (code designation H05RR-F) or ordinary polyvinyl chloride sheathed flexible cords (code designation H05VV-F). ☐

☐ Supply cords of tools intended to be connected to a water supply shall not be lighter than ordinary polychloroprene-sheathed flexible cord (code designation H05 RN-F). ☐

Non-detachable flexible cables or cords of class I tools shall be provided with a core marked green/yellow, which is connected to the earthing terminal of the tool and to the earthing contact of the plug (if fitted).

Compliance is checked by inspection and by measurement.

☐ 23.3 If a tool is provided with a plug, the plug shall conform with the requirements laid down in IEC 60083, EN 60309-1 or EN 60309-2. ☐

23.4 The nominal cross-sectional area of flexible cables or cords shall be not less than that shown in Table 8.

Table 8 — Minimum cross-sectional area of supply cord

Rated current of tool A	Nominal cross-sectional area mm²
Up to and including 6	0,75
over 6 up to and including 10	1
over 10 up to and including 16	1,5
over 16 up to and including 25	2,5
over 25 up to and including 32	4
over 32 up to and including 40	6
over 40 up to and including 63	10

Compliance is checked by inspection.

23.5 Tools provided with a power supply cord shall have cord anchorages such that the conductors are relieved from strain, including twisting, where they are connected within the tool, and that their covering is protected from abrasion.

For type X flexible cables or cords, it shall be clear as to how the relief from strain is to be obtained and makeshift methods such as tying the cable or cord into a knot or tying the ends with string shall be not used.

Cord anchorages of power supply cords of class II tools shall be of insulating material or, if of metal, be insulated from accessible metal parts by insulation complying with the requirements for supplementary insulation.

For class I tools, the conductors of flexible cables or cords shall be so arranged that, when the cord anchorage fails, the earthing conductor is relieved from strain as long as the phase conductors are in contact with their terminals.

Cord anchorages of power supply cords of tools other than class II shall be of insulating material or be provided with an insulating lining, if otherwise an insulation fault on the cable or cord could make accessible metal parts live. This lining shall be fixed to the cord anchorage, unless it is a rubber bushing which forms part of the cord guard specified in 23.6.

Cord anchorages of type X cords shall be so designed that:

- the cable or cord cannot touch clamping screws of the cord anchorage, if these screws are accessible or electrically connected to accessible metal parts;
- the cable or cord is not clamped by a metal screw which bears directly on the cable or cord;
- the components cannot readily be lost when replacing the cable or cord and at least one part is securely fixed to an integral part of the tool;
- replacement of the flexible cable or cord does not require the use of a tool especially designed for this purpose;

- they are suitable for the different types of flexible cable or cord which may be connected, unless the tool is so designed that only one type of cable or cord can be fitted.

Cord anchorages for type X cords shall be so designed that replacement of the flexible cable or cord is easily possible.

NOTE Cord anchorages may be a part of the mains switch.

Screws, if any, which have to be operated when replacing the power supply cord, shall not serve to fix any other component unless, when omitted or incorrectly mounted, they render the tool inoperative or manifestly incomplete or unless the parts which are intended to be fastened by them are not detachable during the replacement of the cord.

Glands shall not be used as cord anchorages for power supply cords.

Compliance is checked by inspection and by the following tests:

The tool is fitted with a flexible cable or cord and the conductors are introduced into the terminals, the terminal screws, if any, being tightened just sufficiently to prevent the conductors from easily changing their position. The cord anchorage is used in the normal way, its clamping screws being tightened with two-thirds of the torque specified in 26.1.

The tests are first made with the lightest permissible type of flexible cable or cord, of the smallest cross-sectional area specified in 24.2, and then with the next heavier type of flexible cable or cord of the largest cross-sectional area specified, unless the tool is so designed that only one type of cable or cord can be fitted.

It shall not be possible to push the cable or cord into the tool to such an extent that the cable or cord, or internal parts of the tool, could be damaged.

The cable or cord is then subjected 100 times to a pull of the value shown in the following table. The pulls are applied at a point 250 mm from the cord guard in the most unfavourable direction without jerks, each time for 1 s.

Immediately afterwards, the sheathed flexible cables or cords are subjected for 1 min to a torque of the value shown in Table 9.

Table 9 — Pull and torque values for power supply cord

Mass of tool kg	Pull N	Torque Nm
<i>Up to and including 1</i>	30	0,1
<i>over 1 up to and including 4</i>	60	0,25
<i>over 4</i>	100	0,35

During the test, the cable or cord shall not be damaged.

After the test, the cable or cord shall not have been longitudinally displaced by more than 2 mm and the conductors shall not have moved over a distance of more than 1 mm in the terminals, nor shall there be appreciable strain at the connection.

For the measurement of the longitudinal displacement, a mark is made on the cable or cord while it is subjected to the pull, at a distance of approximately 20 mm from the cord anchorage before starting the tests.

After the tests, the displacement of the mark on the cable or cord in relation to the cord anchorage is measured while the cable or cord is subjected to the pull.

The cord anchorage is then tightened and loosened ten times, after having fitted the largest flexible cable or cord that can be introduced through the cord guard or shaped inlet bushing specified in 23.6.

After this test, the cord anchorage shall show no damage within the meaning of this standard.

Creepage distances and clearances shall not be reduced below the values specified in clause 27.

23.6 Flexible cables or cords of tools shall be protected against excessive bending at the inlet opening of the tool, by means of a cord guard of insulating material or suitable shaped inlet bushing.

Such guards shall not be integral with a power supply cable or cord for type X attachment.

The guards shall be fixed in a reliable manner, and shall be of such a design that they project outside the tool for a distance beyond the inlet opening of at least five times the overall diameter of the cable or cord delivered with the tool.

Compliance is checked by inspection, by measurement and by the following test:

A tool designed for a power supply cord is fitted with a cord guard, the flexible cable of cord being approximately 100 mm longer than the guard.

The tool is so held that the axis of the cord guard, where the cable or cord leaves it, projects upwards at an angle of 45° to the horizontal when the cable or cord is free from stress.

A mass equal to $10 D^2$ grammes is then attached to the free end of the cable or cord, D being in millimetres, the overall diameter of the flexible cable or cord delivered with the tool.

If the cord guard is temperature sensitive, the test is made at a temperature of $23\text{ °C} \pm 2\text{ °C}$.

Immediately after the mass has been attached, the curvature of the cable or cord shall nowhere be less than $1,5 D$.

23.7 Inlet openings for external wiring shall be so designed that the protective covering of the cable or cord can be introduced without risk of damage.

Inlet openings for flexible cables or cords shall be in insulating material, or be provided with bushings of insulating material, substantially free from ageing effects under conditions of normal use. The openings or bushings shall be so shaped as to prevent damage to the cable or cord.

Inlet bushings shall be reliably fixed and shall not be removable without the aid of a tool.

For class II tools having inlet openings in metal, the bushings shall neither be of rubber nor form part of the cord guard.

For other tools having inlet openings in metal, a bushing, when used, shall not be of rubber, unless it forms part of the cord guard.

Compliance is checked by inspection and manual test.

NOTE Synthetic rubber is not considered to be rubber.

23.8 The space of the power supply cords inside a tool shall be adequate to allow the conductors to be easily introduced and connected, and the covers, if any, fitted without risk of damage to the conductors or their insulation. It shall be possible to check that the conductors are correctly connected and positioned before the cover is fitted.

The removal of covers giving access to terminals for external conductors shall not require the use of a tool specially designed for this purpose.

Class I tools with cords for type X attachment and all class II tools shall be so designed that the uninsulated end of a conductor, should it become free from its terminal, cannot come into contact with accessible metal parts.

Compliance is checked by inspection and by an installation test with cables or flexible cords of the largest cross-sectional area specified in 24.2.

Tools with type X attachment are subjected to the following additional test:

In the case of pillar terminals where the conductors are not separately clamped by a special device at a distance not exceeding 30 mm from the terminal, and in the case of other terminals with screw clamping, the clamping screw or nut is loosened. Without removing the conductor from the conductor space, a force of 2 N is applied to the wire in any direction and adjacent to the terminal, screw or stud. The uninsulated end of the conductor shall not then come into contact with accessible metal parts or any other metal part connected there to.

NOTE 1 For pillar terminals where the conductors are separately clamped by a special device at a distance not exceeding 30 mm from the terminal, the tool is considered to meet the requirement that the uninsulated end of the conductor shall not come into contact with accessible metal parts.

NOTE 2 The special device for clamping the conductors separately may, for example, be a cord anchorage.

24 Terminals for external conductors

24.1 Tools shall be provided with terminals in which connection is made by means of screws, nuts or equally effective devices.

Screws and nuts which clamp external conductors shall have a metric ISO thread. They shall not serve to fix any other component, except that they may also clamp internal conductors if these are so arranged that they are unlikely to be displaced when fitting the supply conductors.

For tools with type X and type M attachments and having a rated input not exceeding 100 W, soldered connections may be used for the connection of external conductors, provided that the conductor is so positioned or fixed that reliance is not placed upon the soldering alone to maintain the conductor in position, unless barriers are provided such that creepage distances and clearances between live parts and other metal parts cannot be reduced to less than 50% of the values specified in 27.1, should the conductor break away at the soldered joint.

☐ For the purpose of the requirements for power supply cords:

- it is not to be expected that two independent fixings will become loose at the same time;
- conductors connected by soldering are not considered to be adequately fixed, unless they are held in place near to the termination, independently of the solder, but "hooking in" before soldering is, in general, considered to be a suitable means for maintaining the conductors of a power supply cord in position, provided the hole through which the conductor is passed is not unduly large.

The terminals of a component (e.g. a switch) built into the tool - on the assumption that they comply with the requirements of this clause - may be used as terminals intended for external conductors.

Switches having connecting leads (pig tails) are allowed if the connection point is within the handle or housing and the cord anchorage of the mains supply cable meets the requirements of 23.5. ☐

24.2 Terminals for type X attachment shall allow the connection of conductors having nominal cross-sectional areas as shown in Table 10.

Table 10 — Conductor cross-sectional areas

Rated current of tool A	Nominal cross-sectional area of flexible cables and cords mm ²
Up to and including 6	0,75 to 1
over 6 up to and including 10	0,75 to 1,5
over 10 up to and including 16	1 to 2,5
over 16 up to and including 25	1,5 to 4
over 25 up to and including 32	2,5 to 6
over 32 up to and including 40	4 to 10
over 40 up to and including 63	6 to 16

Compliance with the requirements of 24.1 and 24.2 is checked by inspection, by measurement and by fitting cables or cords of the smallest and largest cross-sectional areas specified.

24.3 Terminals and terminations for type M attachment shall be suitable for their purpose.

Compliance is checked by inspection and by applying a pull to the connection of 5 N.

24.4 Terminals shall be so fixed that, when the clamping means is tightened or loosened, the terminal does not work loose, internal wiring is not subjected to stress, and creepage distances and clearances are not reduced below the values specified in 27.1.

Compliance is checked by inspection and by measurement after fastening and loosening ten times a conductor of the largest cross-sectional area specified in 24.2, the torque applied being equal to two-thirds of the torque specified in 26.1.

☐ Terminals may be prevented from working loose by fixing with two screws, by fixing with one screw in a recess such that there is no appreciable play or by other suitable means.

The requirement for fixation of terminals does not preclude the provision of supply terminals on switches or similar devices in a recess if, after connection of the supply cable and after repositioning of the switch or similar device in its recess, it can be verified by inspection that these components and the supply cable are, after re-assembly of the tool, in the correct position.

Covering with sealing compound without other means of locking is not considered to be sufficient. Self-hardening resins may, however, be used to lock terminals which are not subject to torsion in normal use. ☐

24.5 Terminals shall be so designed that they clamp the conductor between metal surfaces with sufficient contact pressure and without damage to the conductor.

24.6 Terminals of tools having a rated current not exceeding 16 A shall not require special preparation of the conductor in order to effect correct connection, and they shall be so designed or placed that the conductor cannot slip out when the clamping screws or nuts are tightened.

Compliance with the requirements of 24.5 and 24.6 is checked by inspection of the terminals and of the conductors, after the test of 24.4.

☐ The term "special preparation of the conductor" covers soldering of the strands, use of cable lugs, formation of eyelets, etc., but not the reshaping of the conductor before its introduction into the terminal or the twisting of a stranded conductor to consolidate the end.

Conductors are considered to be damaged if they show deep or sharp indentations. ☐

24.7 Pillar-type terminals shall have dimensions as shown in Table 11, except that the length of the thread in the pillar may be reduced, if the mechanical strength is adequate and at least two full threads are in engagement when a conductor of the smallest cross-sectional area specified in 24.2 is tightly clamped.

Table 11 — Dimensions of pillar-type terminals

Rated current of tool	Minimum nominal thread diameter	Minimum diameter of hole for conductor	Minimum length of thread in pillar	Maximum difference between diameter of hole and nominal thread diameter
A	mm	mm	mm	mm
up to and including 6	2,5	2,5	1,8	0,5
over 6 up to and including 10	3,0	3,0	2,0	0,6
over 10 up to and including 16	3,5	3,5	2,5	0,6
over 16 up to and including 25	4,0	4,0	3,0	0,6
over 25 up to and including 32	4,0	4,5	3,0	1,0
over 32 up to and including 40	5,0	5,5	4,0	1,3
over 40 up to and including 63	6,0	7,0	4,0	1,5

The length of the threaded part of the terminal screw shall not be less than the sum of the diameter of the hole for the conductor and the length of the thread in the pillar.

The surface against which the conductor is clamped shall be free from sharp indentations or projections.

Such terminals shall be so designed and located that the end of a conductor introduced into the hole is visible or can pass beyond the threaded hole for a distance at least equal to half the nominal diameter of the screw, or 2,5 mm, whichever is the greater.

☐ If the thread in the pillar is recessed, the length of headed screws must be increased accordingly.

The part against which the conductor is clamped need not be in one piece with the part carrying the clamping screw. ☐

NOTE The length of the thread in the pillar is measured to the point where the thread is first broken by the hole for the conductor.

24.8 Screw-type terminals shall have dimensions not less than those shown in Table 12, except that the length of the thread in the screw hole or nut and the length of thread on the screw may be reduced, if the mechanical strength is adequate and at least two full threads are in engagement when a conductor of the largest cross-sectional area specified in 24.2 is lightly clamped.

If the required length of thread in a terminal screw hole is obtained by plunging, the edge of the extrusion shall be reasonably smooth and the length of thread shall exceed the specified minimum value by at least 0,5 mm. The length of the extrusion shall be not more than 80% of the original thickness of the metal, unless the mechanical strength is adequate with a greater length.

If an intermediate part, such as a pressure plate, is used between the head of the screw and the conductor, the length of thread on the screw shall be increased accordingly, but the diameter of the head of the screw may be reduced by:

- 1 mm for rated currents not exceeding 16 A;
- 2 mm for rated currents exceeding 16 A.

Such an intermediate part shall be locked against rotation.

If an intermediate part has more than one screw, screws with the following nominal thread diameter may be used:

- 3,5 mm for rated currents not exceeding 25 A;
- 4,0 mm for rated currents exceeding 25 A.

☐ If the thread in the screw hole or nut is recessed, the length of headed screws must be increased accordingly. ☐

Table 12 — Dimensions of screw-type terminals

Rated current of tool A	Nominal thread diameter mm	Length of thread on screw mm	Length of thread in screw hole or nut mm	Nominal difference between diameter of head and shank of screw mm	Height of fused of screw mm
Up to and including 6	2,5	4,0	1,5	2,5	1,5
over 6 up to and including 10	3,0	4,0	1,5	3,0	1,8
over 10 up to and including 16	3,5	4,0	1,5	2,5	2,0
over 15 up to and including 25	4,0	5,5	2,5	4,0	2,4
over 25 up to and including 32	5,0	7,5	3,0	5,0	3,5
over 32 up to and including 40	5,0	9,0	3,5	5,0	3,5
over 40 up to and including 63	6,0	10,5	3,5	6,0	5,0

24.9 Stud-type terminals shall be provided with washers and shall have dimensions as shown in Table 13.

Table 13 — Dimensions of stud-type terminals

Rated current of tool A	Nominal thread diameter (minimum) mm	Difference between thread diameter and	
		inner diameter of washers (maximum) mm	outer diameter of washers (minimum) mm
up to and including 6	2,5	0,4	3,5
over 6 up to and including 10	3,0	0,4	4,0
over 10 up to and including 16	3,5	0,4	4,5
over 16 up to and including 25	4,0	0,5	5,0
over 25 up to and including 32	4,0	0,5	5,5

Compliance with the requirements of 24.7 to 24.9 is checked by inspection, by measurement and, if necessary, by the tests of 24.10. A negative deviation of 0,15 mm is allowed for the nominal thread diameter and for the nominal difference between diameters of head and shank of the screw.

☐ If one or more of the dimensions required in 24.7 to 24.9 are larger than specified, the other dimensions need not be correspondingly increased, but departures from the specified values must not impair the function of the terminal.

☐

24.10 If the length of thread in the pillar, screw hole or nut, or the length of thread on the screw, is smaller than that shown in the relevant table, or if the length of the extrusion is more than 80% of the original thickness of the metal, the mechanical strength of the terminal is checked by the following tests:

Screws and nuts are subjected to the test of 26.1 but with the torque increased to 1,2 times the torque specified.

After this test, the terminal shall show no damage impairing its further use.

A conductor is then fastened, as specified in 24.4, once more and, while clamped, is subjected for 1 min to an axial pull, applied without jerks, of the value shown in Table 14.

Table 14 — Axial pull values for conductors

Rated current of tool A	Pull N
Up to and including 6	40
over 6 up to and including 10	50
over 10 up to and including 16	50
over 16 up to and including 25	60
over 25 up to and including 32	80
over 32 up to and including 40	90
over 40 up to and including 63	100

During this test, the conductor shall not move noticeably in the terminal.

☐ Text deleted ☐

24.11 Where terminals are provided for type X and type M attachments, each terminal shall be located in proximity to its corresponding terminal, or terminals, of different polarity and to the earthing terminal, if any.

Compliance is checked by inspection.

24.12 Terminal devices shall not be accessible without the aid of a tool.

Compliance is checked by inspection and by manual test.

24.13 Terminations shall be so designed that the conductor is retained in position independently of the termination, before soldering or welding, so that it cannot slip out should the soldering or welding break.

Compliance is checked by inspection.

24.14 Terminals and terminations for type X and, when applicable, type M attachment shall be so located or shielded that should a wire of a stranded conductor escape when the conductors are fitted, there is no risk of accidental connection between live parts and accessible metal parts and, for class II tools, between live parts and metal parts separated from accessible metal parts by supplementary insulation only.

Compliance is checked by inspection, by manual test and by the following test:

A 8 mm length of insulation is removed from the end of a flexible conductor having a nominal cross-sectional area as specified in 23.4. One wire of the stranded conductor is left free and the other wires are fully inserted into and clamped in the terminals.

The free wire is bent, without tearing the insulation back, in every possible direction, but without making sharp bends round barriers.

The free wire of a conductor connected to a live terminal shall not touch any metal part which is accessible or is connected to an accessible metal part or, for class II tools, any metal part which is separated from accessible metal parts by supplementary insulation only. The free wire of a conductor connected to an earthing terminal shall not touch any live part.

Where the method of connection requires special preparation of the conductor, e.g. soldering, or where a termination is fitted to a type M attachment, e.g. crimping, this preparation is done with one strand left free.

25 Provision for earthing

25.1 Accessible metal parts of class I tools, which may become live in the event of an insulation fault, shall be permanently and reliably connected to an earthing termination within the tool or to the earthing contact of the appliance inlet.

Earthing terminals and earthing contacts shall not be electrically connected to the neutral terminal, if any.

Class II and class III tools shall have no provision for earthing.

Compliance is checked by inspection.

Ⓢ *If accessible metal parts are screened from live parts by metal parts which are connected to the earthing terminal or to the earthing contact, they are not, for the purpose of this requirement, regarded as likely to become live in the event of an insulation fault.*

Accessible metal parts which are separated from live parts by double insulation or by reinforced insulation are not considered likely to become live in the event of an insulation fault.

Metal parts behind a decorative cover which does not withstand the test of clause 19 are considered to be accessible metal parts. Ⓢ

25.2 Earthing connections shall not be made using screwless terminals.

The clamping means of earthing terminals shall be adequately locked against accidental loosening and it shall not be possible to loosen them without the aid of a tool.

Compliance is checked by inspection, by manual test and by the test of clause 24.

NOTE In general, the designs commonly used for current-carrying terminals, other than some terminals of the pillar type, provide sufficient resiliency to comply with the latter requirement; for other designs, special provisions, such as the use of an adequately resilient part which is not likely to be removed inadvertently, may be necessary.

25.3 All parts of the earthing terminal shall be such that there is no risk of corrosion resulting from contact between these parts and the copper of the earthing conductor, or any other metal that is in contact with these parts.

The body of the earthing terminal shall be of brass or other metal no less resistant to corrosion, unless it is a part of the metal frame or enclosure, when the screw or nut shall be of brass, plated steel complying with clause 29, or other metal no less resistant to corrosion.

If the body of the earthing terminal is a part of a frame or enclosure of aluminium alloy, precautions shall be taken to avoid the risk of corrosion resulting from contact between copper and aluminium or its alloys.

Compliance is checked by inspection.

NOTE The requirement regarding the avoidance of the risk of corrosion does not preclude the use of adequately coated metal screws or nuts.

25.4 For tools with power supply cords or cables, the arrangement of the terminals, or the length of the conductors between the cord anchorage and the terminals, shall be such that the current-carrying conductors become taut before the earthing conductor if the cable or cord slips out of the cord anchorage.

☐ Text deleted ☐

25.5 The connection between the earthing terminal or earthing contact, and parts required to be connected thereto, shall be of low resistance.

Compliance is checked by the following test, during which any inductors for interference suppression are left in the earthing circuit.

A current of 1,5 times the rated current but not less than 25 A, derived from an a.c. source with a no-load voltage not exceeding 12 V is passed between the earthing terminal or earthing contact, and each of the accessible metal parts in turn.

The voltage drop between the earthing terminal or the earthing contact of the tool, and the accessible metal part is measured, and the resistance calculated from the current and this voltage drop.

In no case shall the resistance exceed 0,1 Ω .

☐ The resistance of the flexible cable or cord is not included in the resistance measurement.

Care is taken that the contact resistance between the tip of the measuring probe and the metal part under test does not influence the test results. ☐

25.6 Terminal screws for earthing conductors shall not serve any other purpose, e.g. mechanical fixing.

26 Screws and connections

26.1 Screwed connections, electrical or otherwise, shall withstand the mechanical stresses occurring in normal use. Screws transmitting contact pressure and screws which are likely to be tightened by the user and have a nominal diameter less than 3 mm shall screw into metal.

Screws shall not be of metal which is soft or liable to creep, such as zinc or pure aluminium.

Screws of insulating material shall have a nominal diameter of at least 3 mm; they shall not be used for any electrical connection.

Screws shall not be of insulating material if their replacement by a metal screw could impair supplementary insulation or reinforced insulation, neither shall screws which may be removed when replacing a power supply cord or undertaking other routine servicing, be of insulating material if their replacement by a metal screw could impair electrical insulation.

Compliance is checked by inspection and, for screws and nuts transmitting contact pressure, or which are likely to be tightened by the user, by the following test.

The screws or nuts are tightened and loosened:

10 times for screws in engagement with a thread of insulating material;

5 times for nuts and other screws.

Screws in engagement with a thread of insulating material are completely removed and reinserted each time.

When testing terminal screws and nuts, a flexible conductor of the largest cross-sectional area specified in 24.2 is placed in the terminal.

The test is made by means of a suitable test screwdriver, spanner or key applying a torque as shown in Table 15, the appropriate column being

- for metal screws without heads if the screw when tightened does not protrude from the hole I
- for other metal screws and for nuts II
- for screws of insulating material:
 - having a hexagonal head with the dimension across flats exceeding the overall thread diameter; or
 - with the cylindrical head and a socket for a key, the socket having a cross-corner dimension exceeding the overall thread diameter; or
 - with a head having a slot or cross slots, the length of which exceeds 1,5 times the overall thread diameter II
- for other screws of insulating material III

Table 15 — Torque values for screwed connections

Nominal diameter of screw mm	Torque Nm		
	I	II	III
Up to and including 2,8	0,2	0,4	0,4
over 2,8 up to and including 3,0	0,25	0,5	0,5
over 3,0 up to and including 3,2	0,3	0,6	0,6
over 3,2 up to and including 3,6	0,4	0,8	0,6
over 3,6 up to and including 4,1	0,7	1,2	0,6
over 4,1 up to and including 4,7	0,8	1,8	0,9
over 4,7 up to and including 5,3	0,8	2,0	1,0
over 5,3 up to and including 6,0	—	2,5	1,25

The conductor is moved each time the screw or nut is loosened.

During the test, no damage impairing the further use of the screwed connections shall occur.

☐ Screws or nuts which are likely to be tightened by the user include terminal screws or nuts, screws for fixing covers, if they have to be loosened to open or to remove the cover, screws for fixing handles, knobs, etc.

The shape of the blade of the test screwdriver must suit the head of the screw to be tested. The screws and nuts must not be tightened in jerks. ☐

26.2 Screws in engagement with a thread of insulating material shall have a length of engagement of at least 3 mm plus one-third of the nominal screw diameter or 8 mm, whichever is the shorter.

Correct introduction of the screw into the screw hole or nut shall be ensured.

☐ This requirement does not apply to brush caps. ☐

Compliance is checked by inspection, by measurement and by manual test.

☐ The requirement with regard to correct introduction is met if introduction of the screw in a slanting manner is prevented, for example, by guiding the screw by the part to be fixed, by a recess in the female thread or by the use of a screw with the leading thread removed. ☐

26.3 Electrical connections shall be so designed that contact pressure is not transmitted through insulating material which is liable to shrink or to distort, unless there is sufficient resiliency in the metallic parts to compensate for any possible shrinkage or distortion of the insulating material.

26.4 Space-threaded (sheet metal) screws shall not be used for the connection of current-carrying parts, unless they clamp these parts directly in contact with each other and are provided with a suitable means of locking.

Thread-cutting (self-tapping) screws shall not be used for the electrical connection of current-carrying parts, unless they generate a full form standard machine screw thread. Such screws shall not, however, be used if they are operated by the user, unless the thread is formed by a swaging action.

Thread-cutting and space-threaded screws may be used to provide earthing continuity, provided that it is not necessary to disturb the connection in normal use and that at least two screws are used for each connection.

Compliance with the requirements of 26.3 and 26.4 is checked by inspection.

26.5 Screws which make a mechanical connection between different parts of the tool shall be locked against loosening, if the connection carries current.

Rivets used for current-carrying connections shall be locked against loosening, if these connections are subject to torsion in normal use.

Compliance is checked by inspection and by manual test.

☐ *Spring washers and the like may provide satisfactory locking.*

For rivets, a non-circular shank or an appropriate notch may be sufficient.

Sealing compound which softens on heating provides satisfactory locking only for screw connections not subject to torsion in normal use. ☐

27 Creepage distances, clearances and distances through insulation

27.1 Creepage distances, clearances and distances through insulation shall not be less than the values in millimetres shown in Table 16.

☐ *Text deleted* ☐

If a resonance voltage occurs between the point where a winding and a capacitor are connected together, and metal parts separated from live parts by basic insulation only, the creepage distance and clearance shall not be less than the values specified for the value of the voltage imposed by the resonance, these values being increased by 4 mm in the case of reinforced insulation.

Compliance is checked by measurement.

For tools provided with an appliance inlet, the measurements are made with an appropriate connector inserted; for tools with type X attachment, they are made with supply conductors of the largest cross-sectional area specified in 24.2, and also without conductors; for other tools they are made on the tool as delivered.

For tools provided with belts, the measurements are made with the belts in place and the devices intended for varying the belt tension adjusted to the most unfavourable position within their range of adjustment, and also with the belts removed.

Movable parts are placed in the most unfavourable position; nuts and screws with non-circular heads are assumed to be tightened in the most unfavourable position.

The clearance between terminals and accessible metal parts are also measured with the screws or nuts unscrewed as far as possible, but the clearances shall then be not less than 50% of the values shown in the Table 16.

Distances through slots or openings in external parts of insulating material are measured to metal foil in contact with the accessible surface; the foil is pushed into corners and the like by means of the standard test finger shown in Figure 1 but it is not pressed into openings.

If necessary, a force is applied to any point on bare conductors, on uninsulated capillary tubes of thermostats and similar devices and to the outside of metal enclosures, in an endeavour to reduce the creepage distances and clearances while taking the measurements.

The force is applied by means of a test finger having a tip as shown in Figure 1 and has a value of

- 2 N for bare conductors and for uninsulated capillary tubes of thermostats and similar devices;
- 30 N for enclosures.

Table 16 — Creepage distances and clearances

Distances mm	Class III tools		Other tools					
			Working voltage up to 130 V		Working voltage over 130 up to 250 V		Working voltage over 250 up to 440 V	
	Creepage distance	Clearance	Creepage distance	Clearance	Creepage distance	Clearance	Creepage distance	Clearance
Between live parts of different polarity ²⁾								
- if protected against deposition of dirt	1,0	1,0	1,0	1,0	2,0	2,0	2,0	2,0
- if not protected against deposition of dirt	2,0	1,5	2,0	1,5	3,0	2,5	4,0	3,0
- if lacquered or enamelled windings	1,0	1,0	1,5	1,5	2,0	2,0	2,0	3,0
Between live parts and other metal parts over basic insulation;								
- if protected against deposition of dirt ³⁾								
- if of ceramic material, pure mica or the like	1,0	1,0	1,0	1,0	2,5 ⁴⁾	2,5 ⁴⁾	—	—
- if of other material	1,5	1,0	1,5	1,0	3,0	2,5 ⁴⁾	—	—
- if not protected against deposition of dirt	2,0	1,5	2,0	1,5	4,0	3,0	—	—
- if the live parts are lacquered or enamelled windings	1,0	1,0	1,5	1,5	2,0	2,0	—	—
- at the end of tubular sheathed-type heating elements ⁵⁾	—	—	1,0	1,0	1,0	1,0	—	—
Between live parts and other metal parts over reinforced insulation:								
- if the live parts are lacquered or enamelled windings	—	—	6,0	6,0	6,0	6,0	—	—
- for other live parts	—	—	8,0	8,0	8,0	8,0	—	—
Between metal parts separated by supplementary insulation	—	—	4,0	4,0	4,0	4,0	—	—
Between live parts in recesses in the mounting face of the appliance and the surface to which it is fixed	2,0	2,0	6,0	6,0	6,0	6,0	—	—

1) The values specified in these columns do not apply to printed wiring circuits, for which values are under consideration.
2) The clearances specified do not apply to the air gap between the contacts of thermal controls, overload protection devices, switches of micro-gap construction and the like, or to the air gap between the current-carrying members of such devices where the clearance varies with the movement of the contacts.
3) In general, the interior of an appliance having a reasonably dust-proof enclosure is considered to be protected against deposition of dirt, provided the appliance does not generate dust within itself, hermetic sealing is not required.
4) If the parts are rigid and located by mouldings, or if the design is otherwise such that there is no likelihood of a distance being reduced by distortion or movement of the parts, this value may be reduced to 2,0.
5) These values apply only to class I appliances.

Ⓒ The requirement concerning distances through insulation between metal parts does not imply that the prescribed distance must be through solid insulation only; it may consist of a thickness of solid insulation plus one or more air layers.

The requirement concerning the distance through insulation between metal parts does not apply if the insulation is applied in thin sheet form and consists of at least three layers, provided that, when two layers are placed in contact, they withstand the electric strength test prescribed for reinforced insulation, the test voltage being applied between the outer surfaces of the two layers.

For live parts of different polarity separated by basic insulation only, creepage distances and clearances smaller than those specified in the table are allowed, provided the appliance does not show any defect within the meaning of this standard, if these creepage distances and clearances are short-circuited and the creepage distances are over insulating material withstanding the test of 28.3.

The way in which creepage distances and clearances are measured is indicated in Annex D.

If a barrier is interposed and if it is in two parts which are not cemented together, the distance is also measured through the joint.

If a barrier is interposed, clearances are measured over the barrier or, if the barrier is in two parts with mating surfaces which are not cemented together, through the joint.

When assessing creepage distances and clearances, the effect of insulating linings of metal enclosures or covers is taken into consideration.

Internal conductors are considered to be bare conductors unless their insulation withstands an electric strength test made between the conductor and the metal foil wrapped round the insulation, a test voltage of 2 000 V being applied for 15 min.

Wirings are considered to have basic insulation if they are wrapped with tape and then impregnated, or if they are covered with a layer of self-hardening resin, and if, after the test of 14.2, an electric strength test as specified in 15.3 is withstood, the test voltage being applied between the conductors of the winding and metal foil in contact with the surface of the insulation. Ⓒ

27.2 The distance through insulation, for working voltages up to and including 250 V, between metal parts, shall not be less than 1,0 mm if they are separated by supplementary insulation, and not be less than 2,0 mm if they are separated by reinforced insulation.

This requirement does not apply if the insulation is applied in this sheet form, other than mica or similar scaly material, and consists:

- for supplementary insulation, of at least two layers, provided that at least one of the layers withstands the electric strength test prescribed for supplementary insulation;
- for reinforced insulation, of at least three layers, provided that, when two of the layers are placed in contact, they withstand the electric strength test prescribed for reinforced insulation;

the test voltage being applied between the outer surfaces of the layer or of the two layers as applicable.

Ⓒ This requirement does not imply that the prescribed distance shall be through solid insulation only; it may consist of a thickness of solid insulation plus one or more air layers.

For tools having parts with double insulation where there is no metal between basic insulation and supplementary insulation, the measurements are made as though a metal foil were present between the two insulations. Ⓒ

27.3 For tools having a rated current exceeding 25 A, the distance between the terminals and metal enclosures shall be at least 9,5 mm.

Compliance with the requirements of 27.2 and 27.3 is checked by inspection and by measurement.

28 Resistance to heat, fire and tracking

28.1 External parts of insulating material, the deterioration of which might cause the tool to become unsafe, shall be sufficiently resistant to heat.

Compliance is checked by subjecting enclosures and other external parts of insulating material to a ball-pressure test by means of the apparatus shown in Figure 8.

The surface of the part to be tested is placed in the horizontal position and a steel ball of 5 mm diameter is pressed against this surface by a force of 20 N.

The test is made in a heating cabinet at a temperature of $75\text{ °C} \pm 2\text{ °C}$ or at a temperature which is $40\text{ °C} \pm 2\text{ °C}$ in excess of the temperature rise of the relevant part determined during the test of clause 11, whichever is the higher.

After 1 h, the ball is removed and the diameter of the impression measured. This diameter shall not exceed 2 mm.

Ⓒ *The test is not made on parts of ceramic material.* **Ⓒ**

28.2 Insulating parts retaining live parts in position shall be resistant to abnormal heat and to fire.

Compliance is checked by the following test:

A test is made as described in 28.1, but at a temperature of $125\text{ °C} \pm 2\text{ °C}$ or at a temperature which is $40\text{ °C} \pm 2\text{ °C}$ in excess of the temperature rise of the relevant part determined during the test of clause 11, whichever is the higher.

In addition, the insulating parts are subjected to a test made with an electrically heated conical mandrel in an apparatus as shown in Figure 9.

The mandrel is inserted into a conical hole reamed in the part to be tested in such a way that portions of the conical part of the mandrel of equal length protrude from both sides. The sample is pressed against the mandrel with a force of 12 N. The means by which the force is applied is then locked to prevent any further movement. However, if the sample starts to soften or melt during the test, a force just sufficient to keep the sample in contact with the mandrel is applied in a horizontal direction.

The mandrel is heated to a temperature of 300 °C in approximately 3 min and is maintained within 10 °C of this value for 2 min. The temperature is measured by means of a thermocouple inside the mandrel.

During the period of 5 min, sparks of about 6 mm in length are produced at the upper surface of the sample where the mandrel protrudes by means of a high-frequency generator, the electrodes of which are moved around the mandrel so as to cover the whole area of the sample near the mandrel.

Neither the sample, nor any gases produced during the heating shall be ignited by the sparks.

Ⓒ *The tests are not made on parts of ceramic material, insulating parts of commutators or brush-caps and the like, or on coil formers not used as reinforced insulation.*

Ⓒ

28.3 Insulating parts retaining live parts in position and supplementary insulation of metal-encased class II tools shall be of material resistant to tracking, if they are exposed to excessive deposition of moisture or dirt in normal use, unless the creepage distances are at least equal to twice the values specified in 27.1.

For materials other than ceramic, compliance is checked by the following test:

A flat surface of the part to be tested, if possible at least $15\text{ mm} \times 15\text{ mm}$, is placed in the horizontal position.

Two electrodes of platinum or other sufficiently non-corrodible material, with the dimensions shown in Figure 10 are placed on the surface of the sample in the manner shown in this figure, so that the rounded edges are in contact with the sample over their whole length.

The force exerted on the surface by each electrode is about 1 N.

The electrodes are connected to a 50 Hz supply source having a voltage of 175 V of substantially sine-wave form. The total impedance of the circuit when the electrodes are short-circuited is adjusted by means of a variable resistor, so that the current is equal to $1,0\text{ A} \pm 0,1\text{ A}$ with a power factor between 0,9 and 1. An overcurrent relay with a tripping time of at least 0,5 s is included in the circuit.

The surface of the sample is wetted by allowing drops of a solution of ammonium chloride in distilled water to fall centrally between the electrodes. The solution has a volume resistivity of $400 \Omega \text{ cm}$ at $25 \text{ }^\circ\text{C}$, corresponding to a concentration of about 0,1%. The drops have a volume of formula 20_0^{+5} mm^3 and fall from a height of 30 mm to 40 mm.

The time interval between one drop and the next is $30 \text{ s} \pm 5 \text{ s}$.

No flashover or breakdown between electrodes shall occur before a total of 50 drops has fallen.

The test is made at three places on the sample.

Ⓒ *Care is taken that the electrodes are clean, correctly shaped and correctly positioned before each test is started.*

In case of doubt, the test is repeated, if necessary on a new sample.

The test is not made on insulating parts of commutators or brush-caps. Ⓒ

29 Resistance to rusting

Ferrous parts, the rusting of which might cause the tool to become unsafe, shall be adequately protected against rusting.

Compliance is checked by the following test:

All grease is removed from the parts to be tested by immersion in carbon tetrachloride or trichlorethane for 10 min.

The parts are then immersed for 10 min in a 10% solution of ammonium chloride in water at a temperature of $20 \text{ }^\circ\text{C} \pm 5 \text{ }^\circ\text{C}$.

Without drying, but after shaking off any drops, the parts are placed for 10 min in a box containing air saturated with moisture at a temperature of $20 \text{ }^\circ\text{C} \pm 5 \text{ }^\circ\text{C}$.

After the parts have been dried for 10 min in a heating cabinet at a temperature of $100 \text{ }^\circ\text{C} \pm 5 \text{ }^\circ\text{C}$, their surfaces shall show no signs of rust.

Ⓒ *Traces of rust on sharp edges and any yellowish film removable by rubbing are ignored.*

For small helical springs and the like, and for parts exposed to abrasion, a layer of grease may provide sufficient protection against rusting. Such parts are only subjected to the test if there is doubt about the effectiveness of the grease film, and the test is then made without previous removal of the grease.

WARNING: When using the liquids specified for the test, adequate precautions must be taken to prevent the inhalation of their vapours. Ⓒ

30 Radiation

Tools shall not emit harmful radiation.

Compliance is checked by test.

A test specification is given in Part 2.

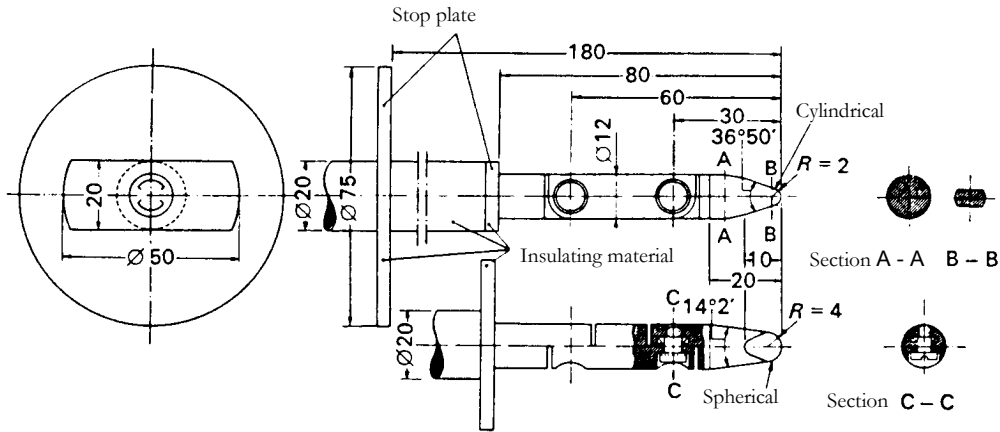

Dimensions in millimetres

Tolerances:

on angles $\pm 5'$

on linear dimensions:

less than 25 mm: $\begin{matrix} 0 \\ -0.05 \end{matrix}$

over 25 mm: ± 0.2

Figure 1 — Standard test finger

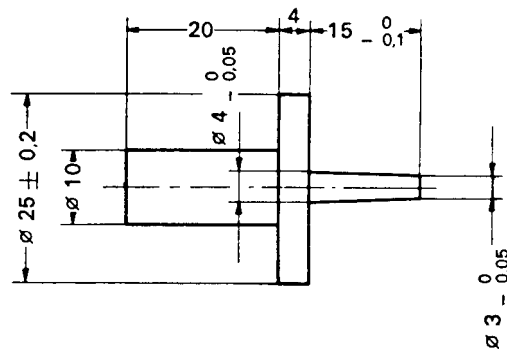

Dimensions in millimetres

Figure 2 — Test pin

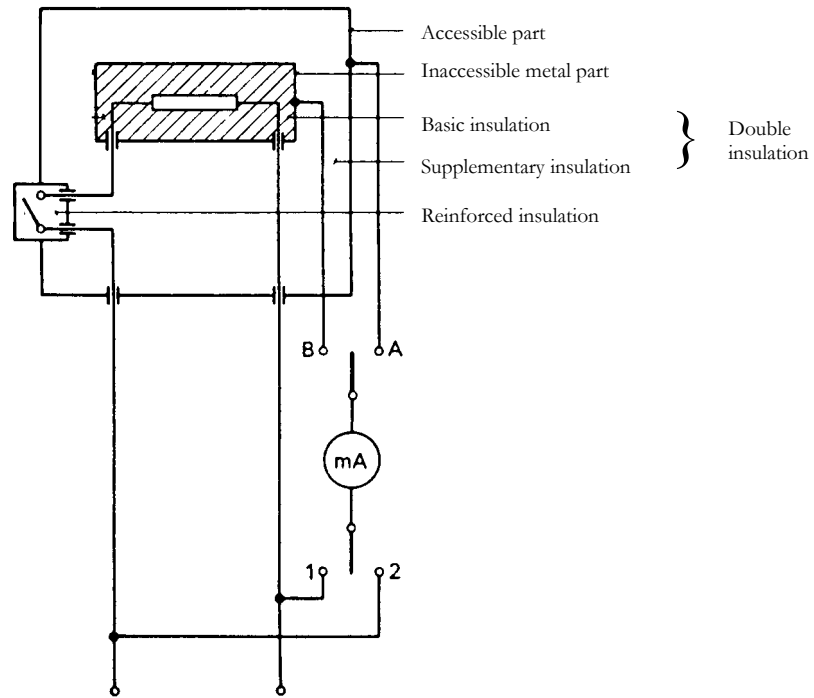

Figure 3 — Diagram for leakage current measurement at operating temperature for single-phase connection of class II tools

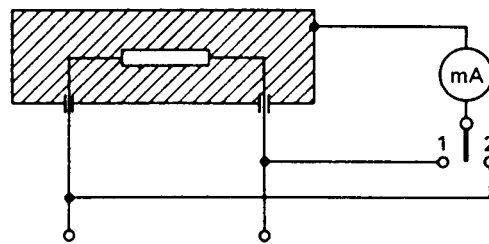

Figure 4 — Diagram for leakage current measurement at operating temperature for single-phase connection of tools other than those of class II

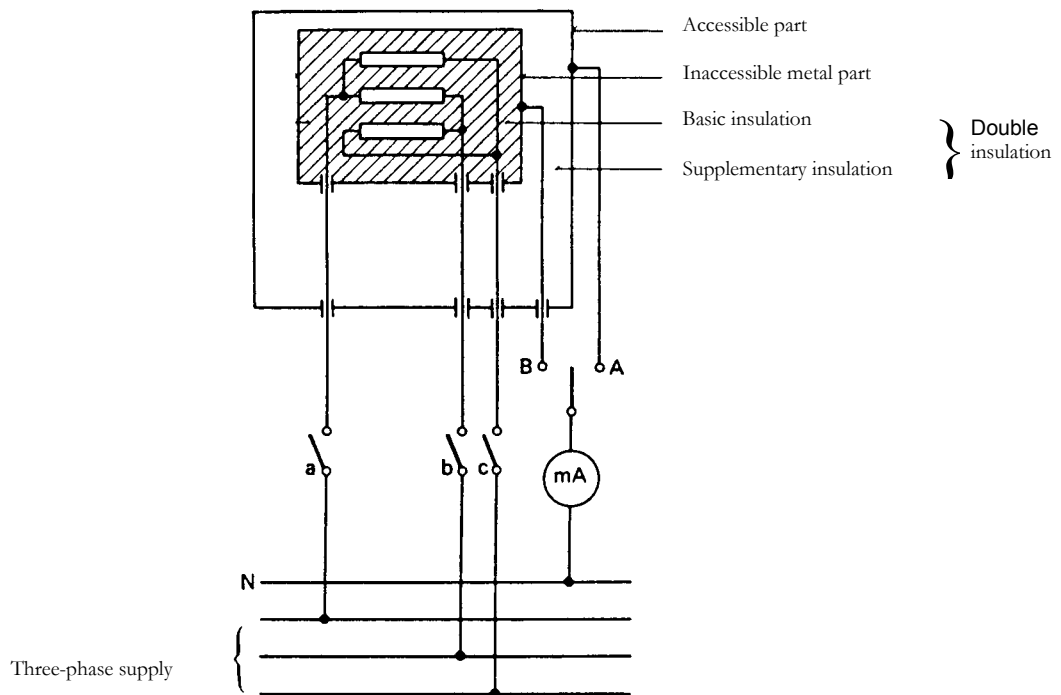

Figure 5 — Diagram for leakage current measurement at operating temperature for three-phase connection of class II tools

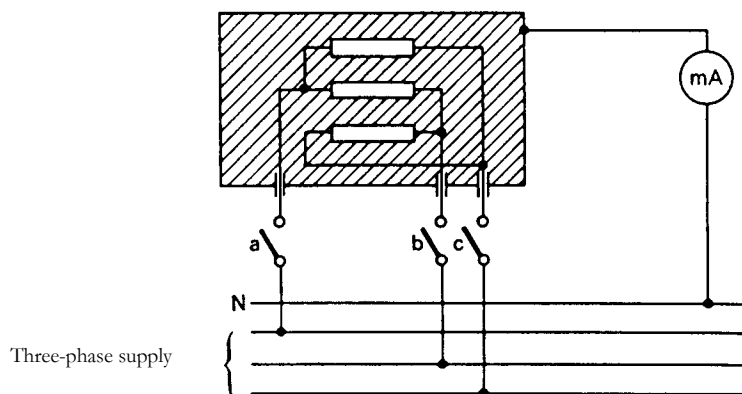

Figure 6 — Diagram for leakage current measurement at operating temperature for three-phase connection of tools other than those of class II

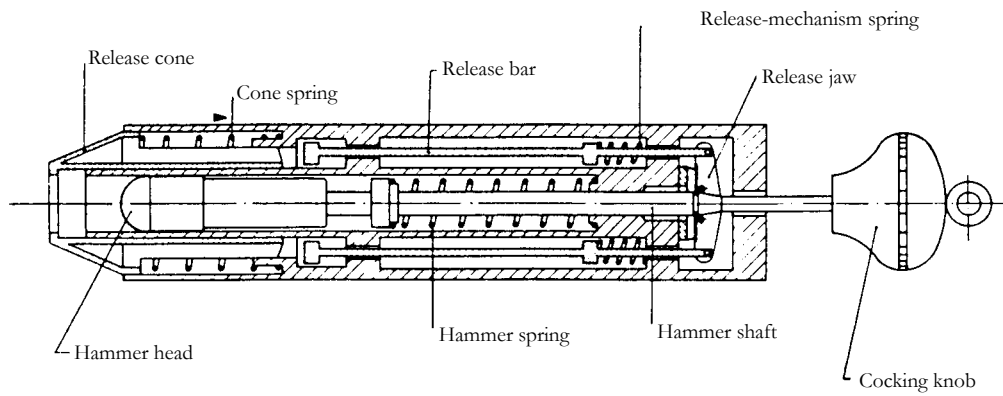

Figure 7 — Impact test apparatus

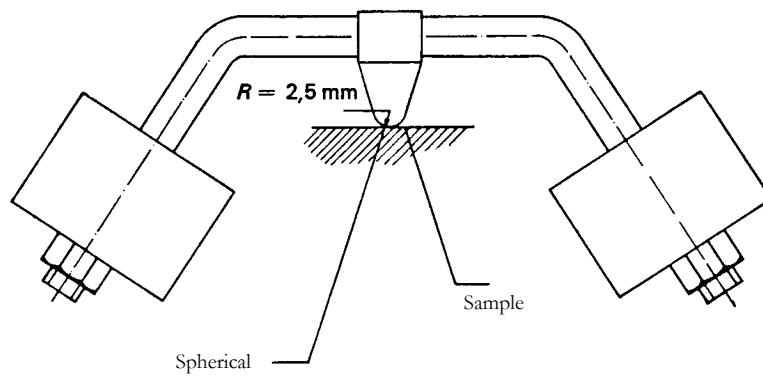

Figure 8 — Ball-pressure apparatus

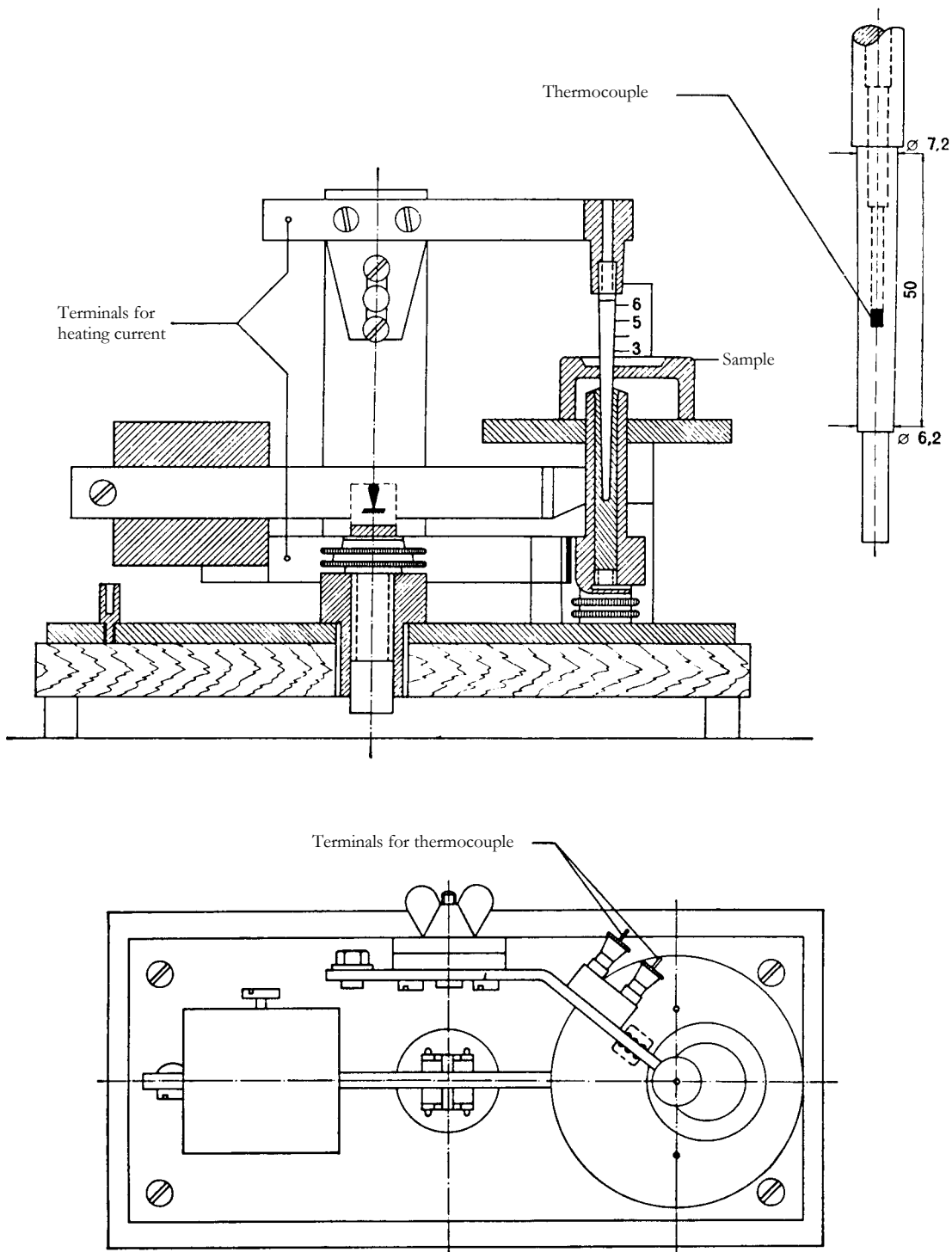

Figure 9 — Hot mandrel apparatus

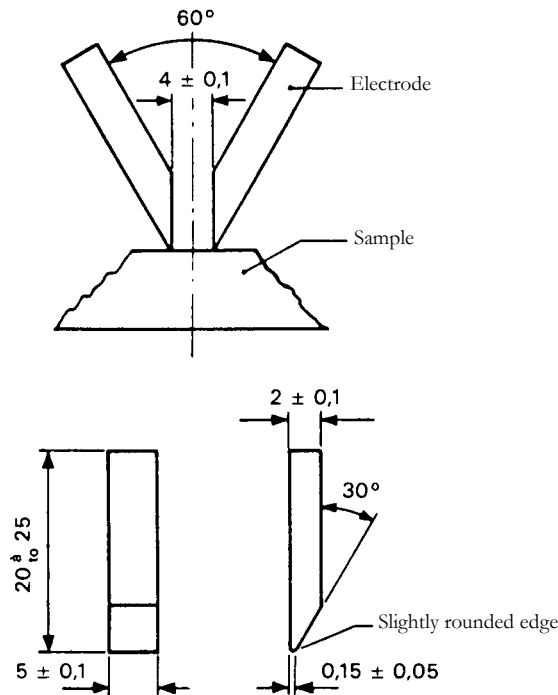
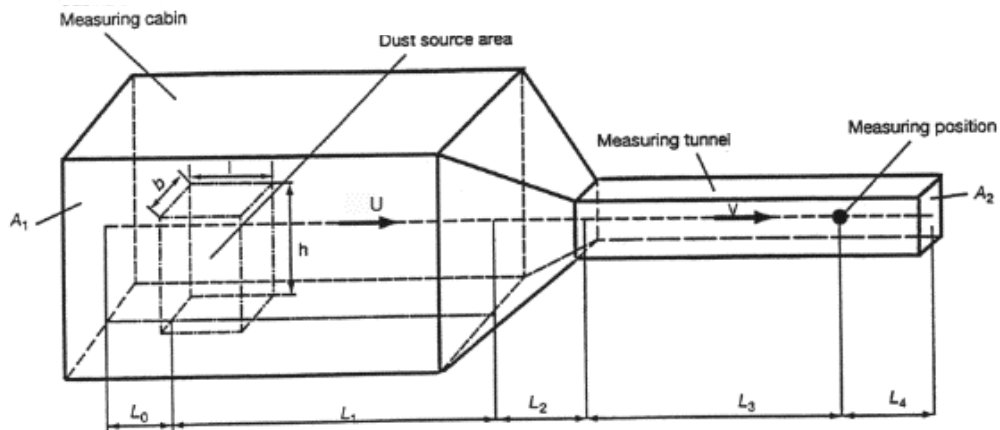

Figure 10 — Arrangement and dimensions of the electrodes for the tracking test

Ⓒ



- A_1 = Inlet cross section = $6,6 \text{ m}^2$ (height: 2,2 m; width: 3 m)
- A_2 = Measuring tunnel cross section = $0,64 \text{ m}^2$ (height: 0,8 m; width: 0,8 m)
- U = Average air velocity in the cabin = $0,25 \text{ ms}^{-1}$
- V = Air flow in tunnel = $1,65 \text{ m}^3\text{s}^{-1} \pm 10\%$
- $L_0 \geq 2 \text{ m}$ $L_1 = 2 \text{ m}$ $L_2 = 1,5 \text{ m}$ $L_3 = 3 \text{ m}$ $L_4 \geq 1 \text{ m}$

NOTE Dimensions L_3 and L_4 deviate from the recommendations of EN 1093-3 for practical reasons and are not expected to significantly affect the validity of the results obtained.

Figure 11 — Test cabin Ⓒ

<http://www.china-gauges.com/>

C

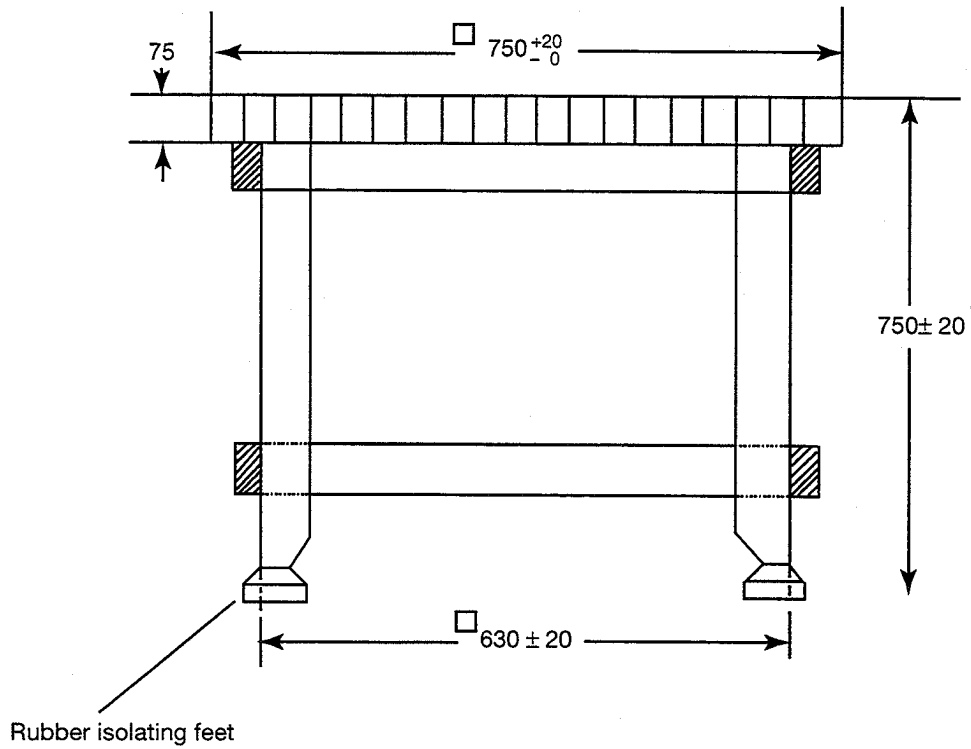

Dimensions in millimetres

Material: pine wood 75 x 40 planed, glued and dowelled

Figure 12 — Test bench for dust measurement C

C11

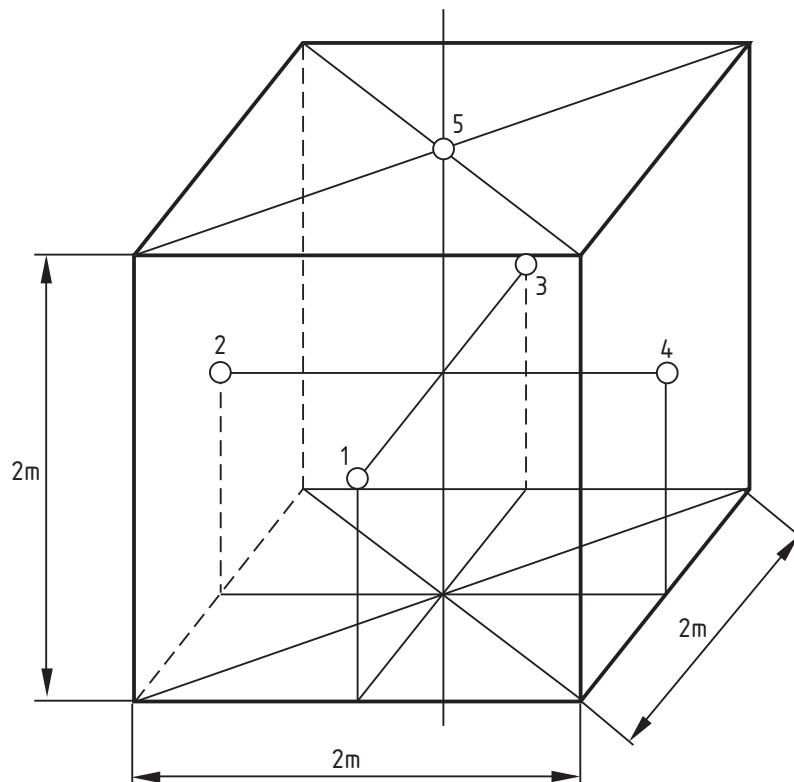

Figure 13 — Microphone for free field measurements over a reflecting plane

C11

<http://www.china-gauges.com/>

Annex A (normative)

Normative references

This European Standard incorporates by dated or undated reference, provisions from other publications. These normative references are cited at the appropriate places in the text and the publications are listed hereafter. For dated references, subsequent amendments to or revisions of any of these publications apply to this European Standard only when incorporated in it by amendment or revision. For undated references the latest edition of the publication referred to applies.

NOTE In this European Standard, all references are to be regarded as undated references.

<u>Publication</u>	<u>Date</u>	<u>Title</u>
EN 292-1	1991	Safety of machinery - Basic concepts, general principles for design Part 1: Basic terminology, methodology
EN 292-2	1991	Safety of machinery - Basic concepts, general principles for design Part 2: Technical principles and specifications
EN 1093-3	1996	Safety of machinery - Evaluation of the emission of airborne hazardous substances -- Part 3: Emission rate of a specified pollutant - Bench test method using the real pollutant
EN 50144-1	1995	Safety of hand-held electric motor operated tools Part 1: General requirements
EN 60065 + corr. June	1998 1999	Audio, video and similar electronic apparatus - Safety requirements (IEC 60065:1998, mod.)
EN 60068-2-75	1997	Environmental testing -- Part 2: Tests - Test Eh: Hammer tests (IEC 60068-2-75:1997)
EN 60127-3	1996	Miniature fuses - Part 3: Sub-miniature fuse-links (IEC 60127-3:1988 + A1:1991 + corrigendum Oct. 1994)
EN 60309-1	1999	Plugs, socket-outlets and couplers for industrial purposes Part 1: General requirements (IEC 60309-1: 1999)
EN 60309-2	1999	Plugs, socket-outlets and couplers for industrial purposes Part 2: Dimensional interchangeability requirements for pin and contact-tube accessories (IEC 60309-2:1999)
EN 60320-1 + A1 + A2	1996 1996 1998	Appliance couplers for household and similar general purposes Part 1: General requirements (IEC 60320-1:1994, mod.; A1:1995 and A2:1996)
EN 60335-1 + corr. Jan. + A1 + A11 + A12 + A13 + A14	1994 1995 1996 1995 1996 1998 1998	Safety of household and similar electrical appliances Part 1: General requirements (IEC 60335-1:1991, mod.) (IEC 60335-1:1991/A1:1996, mod.)
EN 60529 + corr. May	1991 1993	Degrees of protection provided by enclosures (IP Code) (IEC 60529:1989)
EN 60651	1994	Sound level meters (IEC 60651:1979)
EN 60799	1998	Electrical accessories - Cord sets and interconnection cord sets (IEC 60799:1998)
EN 61058-1 + A1	1992 1993	Switches for appliances -- Part 1: General requirements (IEC 61058-1:1990 and A1:1993) 

☐ EN ISO 3744	1995	Acoustics - Determination of sound power levels of noise sources using sound pressure - Engineering method in a essentially free field over a reflecting plane (ISO 3744:1994) ☐
☐ EN ISO 4871	1996	Acoustics – Declaration and verification of noise emission values of machinery and equipment
EN ISO 11201	1995	Acoustics – Noise emitted by machinery and equipment – Measurement of emission sound pressure levels at a work station and at other specified positions – Engineering method in an essentially free field over a reflecting plane ☐
☐ ENV 25349	1992	Mechanical vibration - Guidelines for the measurement and the assessment of human exposure to hand-transmitted vibration (ISO 5349:1986)
ENV 28041	1993	Human response to vibration - Measuring instrumentation (ISO 8041:1990)
HD 21	Series	Polyvinyl chloride insulated cables of rated voltages up to and including 450/750 V (related to IEC 60227 series)
HD 22	Series	Rubber insulated cables of rated voltages up to and including 450/750 V (related to IEC 60245 series)
HD 566 S1	1990	Thermal evaluation and classification of electrical insulation (IEC 60085:1984) ☐
☐ HD 639 S1	2002	Electrical accessories – Portable residual current devices without integral overcurrent protection for household and similar use (PRCDs) (IEC 61540:1997 + A1:1998, mod) ☐
☐ IEC 60083	1997	Plugs and socket-outlets for domestic and similar general use standardized in member countries of IEC
IEC 60384-14	1993	Fixed capacitors for use in electronic equipment Part 14: Sectional specification: Fixed capacitors for electromagnetic interference suppression and connection to the supply mains
ISO 630	1995	Structural steels -- Plates, wide flats, bars, sections and profiles
ISO 820	1975	Particle boards - Definition and classification
ISO 5348	1998	Medical vibration and shock - Mechanical mounting of accelerometers

Informative references

EN 294	1992	Safety of machinery - Safety distances to prevent danger zones being reached by the upper limbs
EN 349	1993	Safety of machinery - Minimum gaps to avoid crushing of parts of the human body
EN 953	1997	Safety of machinery - Guards - General requirements for the design and construction of fixed and movable guards
EN 1088	1995	Safety of machinery - Interlocking devices associated with guards - Principles for design and selection ☐

Annex B (normative)
Thermal cut-outs and overload releases

B.1 Thermal cut-outs and overload releases shall operate reliably.

Compliance is checked by subjecting three samples of the device to a test which is made at 1,25 times the current passing through, and 1,1 times the voltage applied to the device when the tool is operated at rated voltage or at the upper limit of the rated voltage range and under normal load.

The test is made with a.c. or d.c. as appropriate, the test with a.c. being made at the power factor determined when the tool is operated under normal load.

The device is caused to operate 15 times.

After the test, the samples shall show no damage impairing their further use.

B.2 Thermal cut-outs and overload releases shall be so constructed that their setting is not changed appreciably by heating, vibration, etc. occurring in normal use.

Compliance is checked by inspection during the test of clause 16.

Annex C (normative) Electronic circuits

C.1 Scope

This annex applies to circuits comprising at least one electronic component.

C.2 Definitions

Additional definitions:

C.2.101

electronic components

part in which conduction is achieved principally by electrons moving through a vacuum, gas or semi-conductor

C.2.102

protective impedance

impedance connected between live parts and accessible conductive parts, and of a value such that the current, in normal use and under likely fault conditions in the tool, is limited to a safe value

C.4 General notes on tests

Addition:

C.4.1 *All clauses of part 1, as modified in this annex and in the Part 2 for the specific tool, apply to electronic circuits.*

Addition:

C.4.2 *The accumulation of stress resulting from successive tests is to be avoided. It may be necessary to replace components or to use additional samples.*

NOTE The number of additional samples should be kept to a minimum by an evaluation of the relevant circuits.

Additional subclause:

C.4.101 *Care is to be taken that the supply is free from such perturbations from external sources that can influence the results of the tests.*

C.8 Protection against electric shock

C.8.1 The explanation concerning safety extra-low voltage is not applicable.

Addition:

An accessible part is not considered to be live if:

- the part is supplied from a safety isolating transformer, provided that
 - for a.c. the peak value of the voltage does not exceed 42,4 V;
 - for d.c. the voltage does not exceed 42,4 V, or
- the part is separated from live parts by protective impedance.

In the case of protective impedance, the current between the part and the supply source shall not exceed 2 mA for d.c. and its peak value shall not exceed 0,7 mA for a.c., and moreover:

- for voltages having a peak value over 42,4 V up to and including 450 V the capacitance shall not exceed 0,1 μ F;
- ☐ - for voltages having a peak value over 450 V up to and including 15 kV the discharge shall not exceed 45 μ C. ☐

Voltages and currents are measured between the relevant parts and either pole of the supply source. Discharges are measured immediately after the interruption of the supply.

<http://www.china-gauges.com/>

The circuit for measuring the current has a total resistance of $1\,750\ \Omega \pm 250\ \Omega$ and is shunted by a capacitor such that the time constant of the circuit is $225\ \mu\text{s} \pm 15\ \mu\text{s}$. Details of a suitable circuit are given in the informative Annex IA.

NOTE 1 The measuring circuit has an accuracy within 5% for all frequencies in the range of 20 Hz to 5000 Hz.

NOTE 2 For voltages having a peak value over 15 kV other requirements are under consideration.

C.8.6 Addition:

This requirement does not apply to capacitors complying with the requirement for protective impedance.

C.11 Heating

C.11.5 Addition to Table 2:

	<i>Temperature rise</i>
	<i>K</i>
Ⓒ Capacitors complying with IEC 60384-14 or 14.2 of EN 60065	50 Ⓒ
Printed circuit boards bonded with epoxy resin	120
<i>There is no limit for the temperature rise of capacitors which are short-circuited in clause C.17.</i>	

C.12 Leakage current

C.12.1 Addition:

Protective impedance is disconnected from live parts before carrying out the tests.

C.15 Insulation resistance and electric strength

C.15.1 Addition:

Protective impedance is disconnected from live parts before carrying out the tests.

C.15.3 Addition:

The electric strength test between parts of different polarity is not made if the requirements of clause C.17 are met with the parts short-circuited.

C.17 Abnormal operation

Additional subclauses:

C.17.101 Electronic circuits shall be so designed and applied that a fault condition will not render the tool unsafe with regard to electric shock, fire hazard, mechanical hazard or dangerous malfunction.

Compliance is checked by evaluation of the fault conditions specified in C.17.103 for all circuits or parts of circuits, unless they comply with the conditions specified in C.17.102.

Ⓒ *If the safety of the tool under any of the fault conditions depends on the operation of a miniature fuse-link complying with EN 60127-3, the test of C.17.104 is made. **Ⓒ***

During and after each test, the temperature of windings shall not exceed the values specified in Table 5 and the tool shall comply with the conditions specified in 17.1. In particular, live parts shall not be accessible to the standard test finger or the test pin, as specified in 8.1. Any current flowing through protective impedance shall not exceed the limits specified in C.8.1.

If a conductor of a printed circuit board becomes open-circuited, the tool is considered to have withstood the particular test, provided all three of the following conditions are met:

- *the material of the printed circuit board withstands the burning test of 20.1 of EN 60065;*
- *any loosened conductor does not reduce the creepage distances or clearances between live parts and accessible metal parts below the values specified in clause C.27;*
- *the tool withstands the tests of C. 17.103 with the open-circuited conductor bridged.*

NOTE 1 In general, examination of the tool and its circuit diagram will reveal the fault conditions which have to be simulated, so that testing can be limited to those cases which may be expected to give the most unfavourable result.

NOTE 2 In certain cases, it may be preferable to simulate all fault conditions rather than to analyse the circuit diagram.

NOTE 3 In general, the tests take into account any failure which may arise from perturbations on the mains supply. However, where more than one component may be affected simultaneously it may be necessary to carry out additional tests which are under consideration.

C.17.102 Fault conditions 1) to 6) specified in C.17.103 are not applied to circuits or parts of circuits where both of the following conditions are met:

- *the electronic circuit is a low-power circuit as described below;*
- *the protection against electric shock, fire hazard, mechanical hazard or dangerous malfunction in other parts of the tool does not rely on the correct functioning of the electronic circuit.*

A low-power circuit is determined as follows (an example is shown in Figure C.1):

The tool is operated at rated voltage or at the upper limit of the rated voltage range and a variable resistor, adjusted to its maximum resistance, is connected between the point to be investigated and the opposite pole of the supply source.

The resistance is then decreased until the power consumed by the resistor reaches a maximum. Any point nearest to the supply and at which the maximum power delivered to this resistor does not exceed 15 W at the end of 5 s is called a low power point. The part of the circuit farther from the supply source than a low power point is considered to be a low-power circuit.

NOTE 1 The measurements are made from only one pole of the supply source, preferably the one that gives the fewest low power points.

NOTE 2 When determining the low power Points, it is recommended to start with points close to the supply source.

NOTE 3 The power consumed by the variable resistor is measured by a watt-meter.

C.17.103 The following fault conditions are considered and, if necessary, applied one at a time. Consequential faults are taken into consideration.

- 1) *Short circuit of creepage distances and clearances between live parts of different polarity, if these distances are less than the values specified in clause C.27, unless the relevant part is adequately encapsulated.*
- 2) *Short circuit between live parts of different polarity across insulation which does not withstand the tests of clause 15.*
- 3) *Open circuit at the terminals of any component.*
- 4) *Short circuit of capacitors, unless they comply with IEC 60384-14 or 14.2 of EN 60065.*
- 5) *Short circuit of any two terminals of an electronic component, other than integrated circuits.*
- 6) *Failure of an integrated circuit. In this case the possible hazardous situations of the tool are assessed to ensure that safety does not rely on the correct functioning of such a component.*

All possible output signals are considered under fault conditions within the integrated circuit. If it can be shown that a particular output signal is unlikely to occur, then the relevant fault is not considered.

NOTE Microprocessors are regarded as integrated circuits.

In addition, each low-power circuit is short-circuited by connecting the low power point to the pole of the supply from which the measurements were made.

For simulation of the fault conditions, the tool is operated under the conditions specified in clause 11, but at rated voltage or at the most unfavourable voltage within the rated voltage range.

<http://www.china-gauges.com/>

When any of the fault conditions are simulated, the duration of the test is:

- as specified in 11.4, but only for one operating cycle and only if the fault cannot be recognized by the user, for example, change in temperature;
- as specified in 17.1, if the fault can be recognized by the user, for example, when the motor stops;
- until steady conditions are established, for circuits continuously connected to the supply mains, for example, stand-by circuits.

In each case, the test is ended if interruption of the supply occurs within the tool.

Fault condition 5) is not applied between the two circuits of an optocoupler.

If the tool incorporates an electronic circuit which operates to ensure compliance with clause 17, the relevant test is repeated with a single fault simulated, as indicated in 1) to 6) above.

Fault condition 6) is applied to encapsulated and similar components if the circuit cannot be assessed by other methods.

Ⓒ Positive temperature coefficient resistors (PTC's) are not short-circuited if they are used within their manufacturer's declared specification.

Ⓒ

C.17.104 If, for any of the fault conditions specified in C.17.103, the safety of the tool depends on the operation of a miniature fuse-link complying with EN 60127-3, the test is repeated but with the miniature fuse-link replaced by an ammeter.

If the current measured does not exceed 2,1 times the rated current of the fuse-link, the circuit is not considered to be adequately protected and the test is carried out with the fuse-link short-circuited.

If the current measured is at least 2,75 times the rated current of the fuse-link, the circuit is considered to be adequately protected.

If the current measured exceeds 2,1 times the rated current of the fuse-link, but does not exceed 2,75 times the rated current, the fuse-link is short-circuited and the test is carried out

- for quick-acting fuse-link for the relevant period or for 30 min, whichever is the shorter;
- for time-lag fuses for the relevant period or for 2 min, whichever is the shorter.

NOTE 1 In case of doubt, the maximum resistance of the fuse-link has to be taken into account when determining the current.

Ⓒ NOTE 2 The verification whether the fuse-link acts as a protecting device is based on the fusing characteristics specified in EN 60127-3, which also gives the information necessary to calculate the maximum resistance of the fuse-link. Ⓒ

NOTE 3 Other fuses are considered as intentionally weak parts in accordance with 17.1.

C.20 Construction

Additional subclauses:

C.20.101 Parts separated by protective impedance shall comply with the requirements for double or reinforced insulation.

C.20.102 Reinforced insulation is allowed for parts separated by a SELV transformer or protective impedance and for parts separated by an optocoupler.

C.20.103 Protective impedance shall consist of at least two separate components the impedance of which is unlikely to change significantly during the life time of the tool. If one of the components is short-circuited or open-circuited, the values specified in C.8.1 shall not be exceeded.

Compliance is checked by inspection and by measurement.

Ⓒ NOTE Resistors complying with 14.1 and capacitors complying with 14.2 of EN 60065 are considered to comply with this requirement. Ⓒ

C.25 Provision for earthing

C.25.1 Addition:

The printed conductors of printed circuit boards shall not be used to provide continuity of the protective earthing circuit.

C.27 Creepage distances, clearances and distances through insulation

C.27.1 Addition:

For conductive patterns on printed circuit boards, except at their edges, the values in the table between parts of different polarity may be reduced as long as the peak value of the voltage stress does not exceed:

- 150 V per mm with a minimum distance of 0,2 mm, if protected against the deposition of dirt;
- 100 V per mm with a minimum distance of 0,5 mm, if not protected against the deposition of dirt.

For peak voltages exceeding 50 V the reduced creepage distances only apply if the Proof Tracking Index (PTI) of the printed circuit board is greater than 175.

These distances may be reduced further provided that the tool complies with the requirements of clause C. 17 when the distances are short-circuited in turn.

NOTE Where the limits mentioned above lead to higher values than those of the table, the values of the table apply.

For live parts of different polarity separated by basic insulation only, creepage distances and clearances smaller than those specified in the table are allowed provided the requirements of clause C. 17 are met if these creepage distances and clearances are short-circuited in turn.

Creepage distances and clearances within optocouplers are not measured if the individual insulations are adequately sealed and if air is excluded between individual layers of the material.

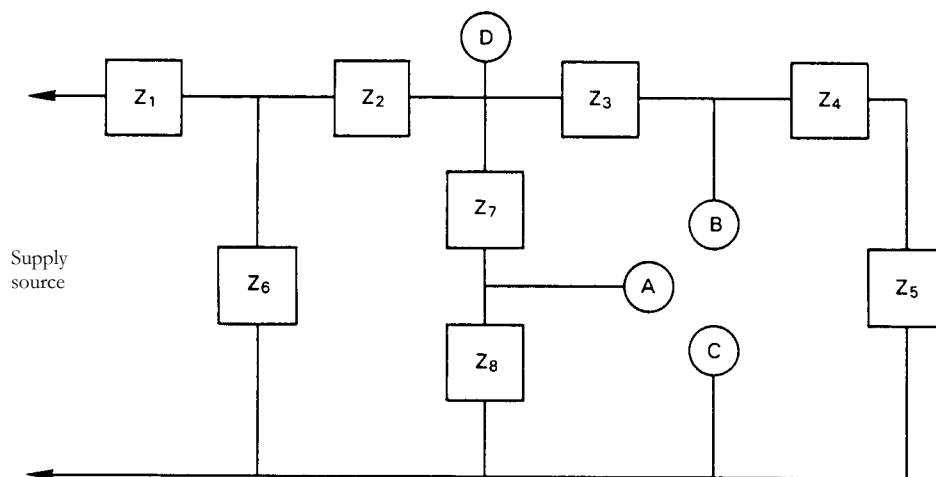

D is a point farthest from the supply source where the maximum power delivered to external load exceeds 15 W.

A and B are points closest to the supply source where the maximum power delivered to external load does not exceed 15 W. They are low-power points.

Points A and B are separately short-circuited to C.

The fault conditions 1) to 6) specified in C.17.103 are applied individually Z_1 , Z_2 , Z_3 , Z_6 and Z_7 , where applicable.

Figure C.1 — Example of an electronic circuit with low power points

Annex D (normative)

Measurement of creepage distances and clearances

The methods of measuring creepage distances and clearances to be used in interpreting the requirements of 27.1 are indicated in Cases 1 to 10 of this annex.

These cases do not differentiate between gaps and grooves, or between types of insulation.

The following assumptions are made.

1. *A groove may have parallel, converging or diverging sides.*
2. *Any groove having diverging sides, a minimum width exceeding 0,25 mm, a depth exceeding 1,5 mm and a width at the bottom equal to or greater than 1 mm, is regarded as an air gap (see case No. 8).*
3. *Any corner including an angle less than 80° is assumed to be bridged with an insulating link of 1 mm width (0,25 mm for dirt-free situations) moved into the most unfavourable position (see case No. 3).*
4. *Where the distance across the top of a groove is 1 mm (0,25 mm for dirt-free situations) or more, no creepage distance exists across the air space (see case No. 2).*
5. *A creepage path is assumed not to exist if there is an air gap as defined in item 2 above exceeding 0,25 mm.*
6. *Creepage distances and clearances measured between parts moving relative to each other are measured when these parts are in their most unfavourable stationary positions.*
7. *A computed creepage distance is never less than a measured clearance.*
8. *Any air gap less than 1 mm wide (0,25 mm for dirt-free situations) is ignored in computing the total clearance.*

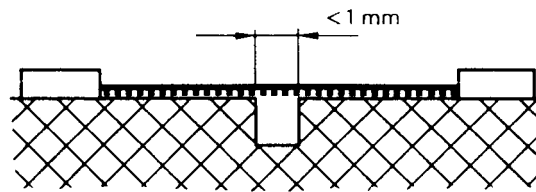

Condition: Path under consideration includes a parallel or converging-sided groove of any depth and with a width less than 1 mm.
Rule: Creepage distance and clearance are measured directly across the groove as shown.

Case No. 1

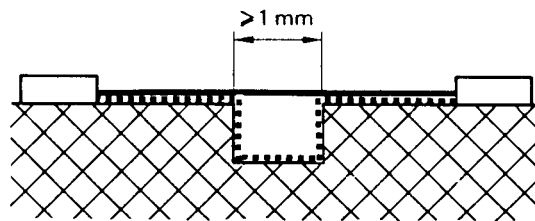

Condition: Path under consideration includes a parallel-sided groove of any depth and with a width equal to or greater than 1 mm.
Rule: Clearance is the "line of sight" distance. Creepage path follows the contour of the groove.

Case No. 2

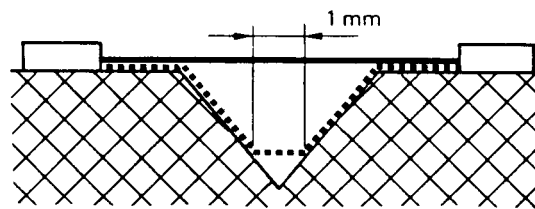

Condition: Path under consideration includes a V-shaped groove with internal angle of less than 80° and with a width greater than 1 mm.

Rule: Clearance is the "line of sight" distance. Creepage path follows the contour of the groove but "short-circuits" the bottom of the groove by 1 mm (0,25 mm for dirt-free situations) link.

Case No. 3

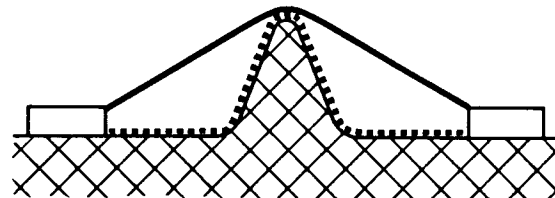

Condition: Path under consideration includes a rib.

Rule: Clearance is the shortest direct air path over the top of the rib. Creepage path follows the contour of the rib.

Case No. 4

— Clearance
..... Creepage distance

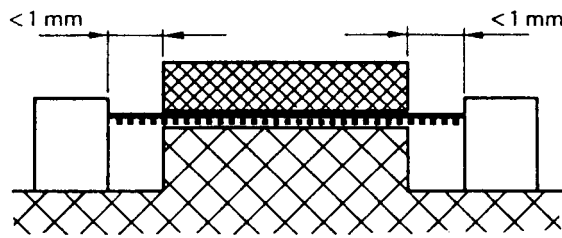

Condition: Path under consideration includes an uncemented joint with grooves less than 1 mm (0,25 mm for dirt-free situations) wide on either side.

Rule: Creepage and clearance path is the "line of sight" distance shown.

Case No. 5

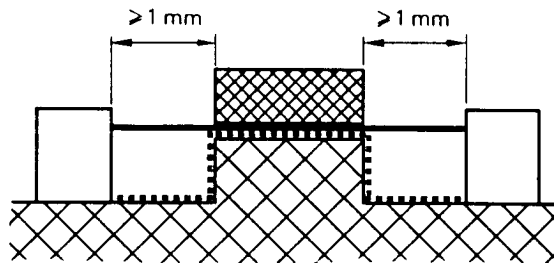

Condition: Path under consideration includes an uncemented joint with grooves equal to or more than 1 mm wide each side.

Rule: Clearance is the "line of sight" distance. Creepage path follows the contour of the grooves.

Case No. 6

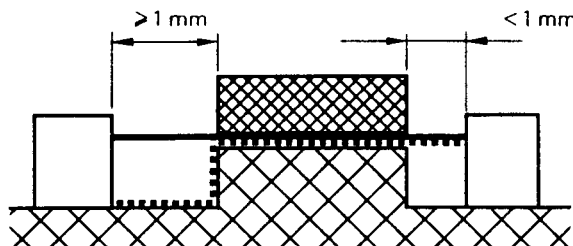

Condition: Path under consideration includes an uncemented joint with a groove on one side less than 1 mm wide and the groove on the other side equal to or more than 1 mm wide.

Rule: Clearance and creepage path are as shown.

Case No. 7

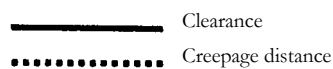

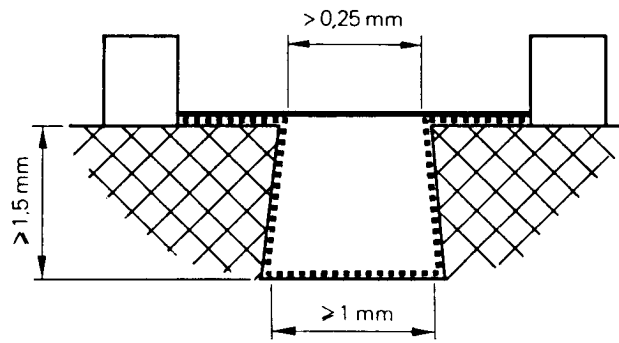

Condition: Path under consideration includes a diverging-sided groove equal to or greater than 1,5 mm deep and greater than 0,25 mm wide at the narrowest parts and equal to or greater than 1 mm at the bottom.

Rule: Clearance is the "line of sight" distance. Creepage path follows the contour of the groove
Case 3 applies as well to an internal corner if the angle is less than 80°.

Case No. 8

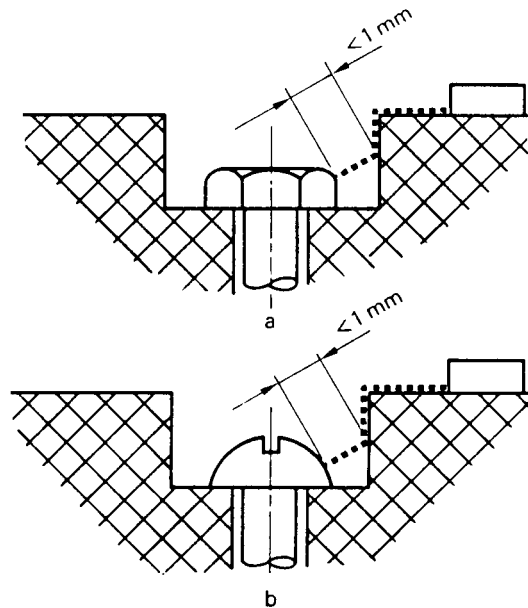

Gap between head of screw and wall of recess too narrow to be taken into account

Case No. 9

— Clearance
..... Creepage distance

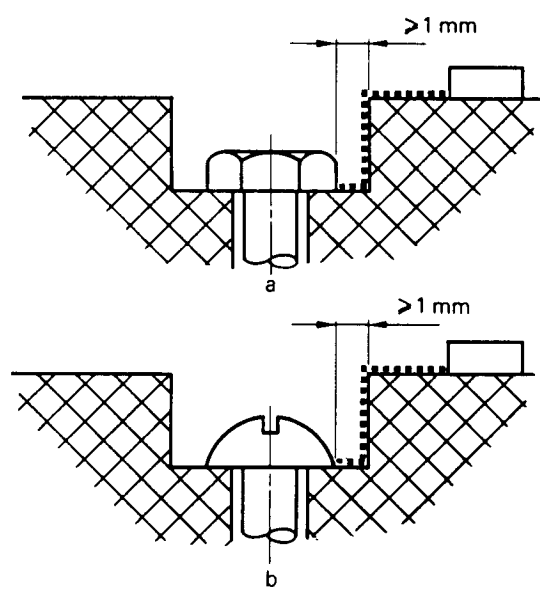

Gap between head of screw and wall of recess wide enough to be taken into account

Case No. 10

..... Creepage distance

Annex IA (informative)

Circuit for measuring leakage currents

A suitable circuit for measuring leakage currents is shown in Figure IA1.

The circuit comprises a rectifier arrangement with germanium diodes D and a moving-coil meter M, resistors and a capacitor C for adjusting the characteristics of the circuit, and a "make-before-break" switch S for adjusting the current range of the instrument.

The measuring circuit has a total resistance of $1\,750\ \Omega \pm 250\ \Omega$ and is shunted by a capacitor such that the time constant of the circuit is $225\ \mu\text{s} \pm 15\ \mu\text{s}$ and has an accuracy within 5% for all frequencies in the range of 20 Hz to 5 000 Hz.

The most sensitive range of the complete instrument must not exceed 1,0 mA, higher ranges being obtained by shunting the coil of the meter by non-inductive resistors R_s and simultaneously adjusting the series resistors RV so as to maintain the total resistance $R_1 + RV + R_m$ of the circuit at the value specified.

The basic calibration points, at a sinusoidal frequency of 50 Hz or 60 Hz, are 0,25 mA, 0,5 mA and 0,75 mA.

NOTE 1 The circuit may be protected against overcurrents, but the method chosen must not affect the characteristics of the circuit.

NOTE 2 The resistance R_m is calculated from the voltage drop measured across the rectifier arrangement at 0,5 mA, the resistance RV being then adjusted so as to give the total resistance of the circuit for each range.

NOTE 3 The measuring arrangement has an accuracy within 5% for all frequencies in the range of 20 Hz to 5 000 Hz.

NOTE 4 Where leakage currents exceeding 5 mA are measured in a circuit having a total resistance less than $1\,600\ \Omega$ the readings are reduced by 5%.

Germanium diodes are used, because these have a lower voltage drop than other types of diode, thus resulting in a more linear scale; preference is given to gold bonded types. The rating of the diodes must be chosen so as to suit the desired maximum range of the complete instrument; however, this range must not exceed 25 mA, because diodes suitable for higher currents have a high voltage drop.

It is recommended that the switch be so arranged that it automatically returns to the position giving the highest current range, in order to prevent inadvertent damage to the instruments.

The capacitor may be made up by selecting capacitors having preferred values and using a series/parallel arrangement.

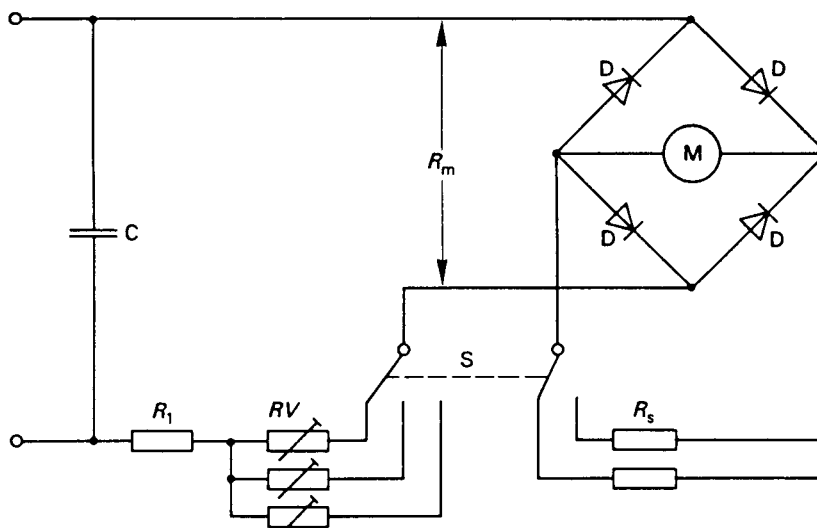

Figure IA.1 — Circuit for measuring leakage currents

Ⓒ Annex ZA (informative)

Rules for routine tests

The tests specified in this annex are intended to reveal, as far as safety is concerned, unacceptable variations in material or manufacture. These production tests do not impair the properties and the reliability of the tool, and should be made by the manufacturer on each tool.

NOTE 1 In general, more tests, such as repetition of type tests and sampling tests, have to be made by the manufacturer to ensure that every tool conforms with the samples that withstood the tests of this specification. The experience gained by the manufacturer will help to determine the extent of the tests required.

NOTE 2 The manufacturer may use a test procedure which is better suited to his production arrangements and may make the tests at an appropriate stage during production provided it can be shown that tools which withstand the tests carried out: by the manufacturer provide at least the same degree of safety as tools which withstand the tests specified in this annex.

NOTE 3 For tools covered by a Part 2, additional tests may be necessary.

ZA.1 Correct operation test

The safe operation shall be checked, for example, by electrical measurements, by verifying the functional devices, such as switches and manually-operated controls, and by verifying the direction of rotation of motors.

ZA.2 Electric strength test

The insulation of the tools shall be checked by the following test.

A voltage of substantially sine-wave form, having a frequency of 50 Hz and the value shown in Table ZA.1 is immediately applied, for 3 s, between live parts and:

- a) accessible metal parts which may become live in the event of an insulation fault or as a result of incorrect assembly;
- b) inaccessible metal parts.

Table ZA.1

<i>Application of test voltage</i>	<i>Test voltage</i>		
	<i>V</i>		
	<i>Class III tools</i>	<i>Class II tools</i>	<i>Class I tools</i>
<i>Over basic insulation</i>	400	1000	1000
<i>Over double insulation or reinforced insulation</i>	2500		

No flashover or breakdown shall occur during the test.

NOTE 1 The tests of item a) are made on the assembled tool: the test of item b) is made on the tool, either completely or partially assembled, in the production line.

NOTE 2 The tests of item a) are made on all tools, the tests of item b) being only made on class II tools.

NOTE 3 The high-voltage transformer used for the tests shall be so designed that when the output terminals are short-circuited after the output voltage has been adjusted to the appropriate test voltage, the output current is at least 200 mA.

NOTE 4 The overcurrent relay shall trip when the output current exceeds 5 mA.

Care shall be taken that the r.m.s. value of the test voltage is measured and measuring device or other indicator responds to the output voltage of the transformer.

Attention is drawn to the fact that the test described cannot always be used if the tool incorporates d.c. components: in such cases, tests with d.c. may be necessary.

The inherent resistance of the d.c. source shall allow short-circuit current of at least 200 mA. Ⓒ

ZA.3 Earthing continuity test

For class I tools, a current of at least 10 A, derived from an a.c. source having a no-load voltage not exceeding 12 V, is passed between the earthing terminal or the earthing contact and, in turn, each of the accessible metal parts which need to be earthed for safety reasons.

The voltage drop between the earthing contact of the plug or the external end of an earth continuity conductor or of the appliance inlet and the accessible metal part is measured, and the resistance calculated from the current and this voltage drop.

In no case shall the resistance exceed 0,3 Ω .

This value is applicable to supply cable lengths up to 5 m.

In case of supply cables having lengths exceeding 5 m, it is increased by 0,12 Ω for any further cable length of 5 m.

NOTE Care shall be taken that the contact resistance between the tip of the measuring probe and the metal parts under test does not influence the test results. **C**

Ⓒ Annex ZB (normative)
Special national conditions

Special national condition: National characteristic or practice that cannot be changed even over a long period, e.g. climatic conditions, electric earthing conditions. If it affects harmonization, it forms part of the European Standard or Harmonization Document.

For the countries in which the relevant special national conditions apply these provisions are normative, for other countries they are informative.

<u>Clause</u>	<u>Special national condition</u>
7.13	In Denmark supply cords of class I transportable tools, which are supplied without a plug, shall be provided with a visible tag containing the following text:

Vigtigt!

Lederen med grøn/gul isolation
må kun tilsluttes en klemme mærket



(Important!)

The conductor having green/yellow insulation
shall only be connected to a terminal marked 

If it is essential for the safety of the tool, the tag shall be provided either with a wiring diagram showing the connection of the other conductors or with the following text:

For tilslutning af de øvrige ledere,
se medfølgende installationsvejledning.

(For the connection of the other conductors,
see the enclosed instructions for installation.)

22.5	In Denmark socket-outlets for providing power to other equipment shall be in accordance with the Danish Heavy Current Regulations, Section 107-2-D1, standard sheet DK 1-3a.
------	--

23.3	In Denmark, for single-phase class I tools the plug according to IEC 60083 shall be replaced by a plug according to the Danish Heavy Current Regulations, Section 107-2-D1, standard sheet DK 2-1a.
------	---

For poly-phase tools with a supply cord provided with a plug this plug shall comply with the Danish Heavy Current Regulations, Section 107-2-D1 or EN 60309-2. **Ⓒ**

<http://www.china-gauges.com/>

BSI — British Standards Institution

BSI is the independent national body responsible for preparing British Standards. It presents the UK view on standards in Europe and at the international level. It is incorporated by Royal Charter.

Revisions

British Standards are updated by amendment or revision. Users of British Standards should make sure that they possess the latest amendments or editions.

It is the constant aim of BSI to improve the quality of our products and services. We would be grateful if anyone finding an inaccuracy or ambiguity while using this British Standard would inform the Secretary of the technical committee responsible, the identity of which can be found on the inside front cover. Tel: +44 (0)20 8996 9000. Fax: +44 (0)20 8996 7400.

BSI offers members an individual updating service called PLUS which ensures that subscribers automatically receive the latest editions of standards.

Buying standards

Orders for all BSI, international and foreign standards publications should be addressed to Customer Services. Tel: +44 (0)20 8996 9001. Fax: +44 (0)20 8996 7001. Email: orders@bsi-global.com. Standards are also available from the BSI website at <http://www.bsi-global.com>.

In response to orders for international standards, it is BSI policy to supply the BSI implementation of those that have been published as British Standards, unless otherwise requested.

Information on standards

BSI provides a wide range of information on national, European and international standards through its Library and its Technical Help to Exporters Service. Various BSI electronic information services are also available which give details on all its products and services. Contact the Information Centre. Tel: +44 (0)20 8996 7111. Fax: +44 (0)20 8996 7048. Email: info@bsi-global.com.

Subscribing members of BSI are kept up to date with standards developments and receive substantial discounts on the purchase price of standards. For details of these and other benefits contact Membership Administration. Tel: +44 (0)20 8996 7002. Fax: +44 (0)20 8996 7001. Email: membership@bsi-global.com.

Information regarding online access to British Standards via British Standards Online can be found at <http://www.bsi-global.com/bsonline>.

Further information about BSI is available on the BSI website at <http://www.bsi-global.com>.

Copyright

Copyright subsists in all BSI publications. BSI also holds the copyright, in the UK, of the publications of the international standardization bodies. Except as permitted under the Copyright, Designs and Patents Act 1988 no extract may be reproduced, stored in a retrieval system or transmitted in any form or by any means – electronic, photocopying, recording or otherwise – without prior written permission from BSI.

This does not preclude the free use, in the course of implementing the standard, of necessary details such as symbols, and size, type or grade designations. If these details are to be used for any other purpose than implementation then the prior written permission of BSI must be obtained.

Details and advice can be obtained from the Copyright & Licensing Manager. Tel: +44 (0)20 8996 7070. Fax: +44 (0)20 8996 7553. Email: copyright@bsi-global.com.

BSI
389 Chiswick High Road
London
W4 4AL