



## ISO 6533:2001(E)

### PDF disclaimer

This PDF file may contain embedded typefaces. In accordance with Adobe's licensing policy, this file may be printed or viewed but shall not be edited unless the typefaces which are embedded are licensed to and installed on the computer performing the editing. In downloading this file, parties accept therein the responsibility of not infringing Adobe's licensing policy. The ISO Central Secretariat accepts no liability in this area.

Adobe is a trademark of Adobe Systems Incorporated.

Details of the software products used to create this PDF file can be found in the General Info relative to the file; the PDF-creation parameters were optimized for printing. Every care has been taken to ensure that the file is suitable for use by ISO member bodies. In the unlikely event that a problem relating to it is found, please inform the Central Secretariat at the address given below.

© ISO 2001

All rights reserved. Unless otherwise specified, no part of this publication may be reproduced or utilized in any form or by any means, electronic or mechanical, including photocopying and microfilm, without permission in writing from either ISO at the address below or ISO's member body in the country of the requester.

ISO copyright office  
Case postale 56 • CH-1211 Geneva 20  
Tel. + 41 22 749 01 11  
Fax + 41 22 749 09 47  
E-mail [copyright@iso.ch](mailto:copyright@iso.ch)  
Web [www.iso.ch](http://www.iso.ch)

Printed in Switzerland

## Foreword

ISO (the International Organization for Standardization) is a worldwide federation of national standards bodies (ISO member bodies). The work of preparing International Standards is normally carried out through ISO technical committees. Each member body interested in a subject for which a technical committee has been established has the right to be represented on that committee. International organizations, governmental and non-governmental, in liaison with ISO, also take part in the work. ISO collaborates closely with the International Electrotechnical Commission (IEC) on all matters of electrotechnical standardization.

International Standards are drafted in accordance with the rules given in the ISO/IEC Directives, Part 3.

The main task of technical committees is to prepare International Standards. Draft International Standards adopted by the technical committees are circulated to the member bodies for voting. Publication as an International Standard requires approval by at least 75 % of the member bodies casting a vote.

Attention is drawn to the possibility that some of the elements of this International Standard may be the subject of patent rights. ISO shall not be held responsible for identifying any or all such patent rights.

ISO 6533 was prepared by Technical Committee ISO/TC 23, *Tractors and machinery for agriculture and forestry*, Subcommittee SC 17, *Manually portable forest machinery*.

This third edition cancels and replaces the second edition (ISO 6533:1993), which has been technically revised.



# Forestry machinery — Portable chain-saw front hand-guard — Dimensions and clearances

## 1 Scope

This International Standard specifies the dimensions and clearances for front hand-guards on portable hand-held chain-saws. These dimensions and clearances ensure the necessary safety provided by the hand-guard, which serves as both a shield between the operator's hand and the saw chain and as an actuator for manually operated chain brakes. This International Standard is not applicable to chain-saws with wraparound handles.

## 2 Normative reference

The following normative document contains provisions which, through reference in this text, constitute provisions of this International Standard. For dated references, subsequent amendments to, or revisions of, any of these publications do not apply. However, parties to agreements based on this International Standard are encouraged to investigate the possibility of applying the most recent edition of the normative document indicated below. For undated references, the latest edition of the normative document referred to applies. Members of ISO and IEC maintain registers of currently valid International Standards.

ISO 6531, *Machinery for forestry — Portable hand-held chain-saws — Vocabulary*

## 3 Terms and definitions

For the purposes of this International Standard, the terms and definitions given in ISO 6531 apply.

## 4 General

The dimensions of the front hand-guard and the clearances shall be in relation to the intended position of the left hand on the front handle during vertical cutting (bucking), determined using defined gauges (see clause 5).

Unless otherwise specified, the following is applicable when determining the dimensions and clearances:

- a) the chain-saw shall be kept in the upright position;
- b) forces applied to the gauges shall not exceed 10 N;
- c) if the front hand-guard also activates the chain brake, the measurements shall be made
  - with the front hand-guard in the non-activated position, and
  - with a maximum force of 10 N applied, at 45° in a forward and downward direction relative to the guidebar centreline and 50 mm to the left of the reference point  $X_0$  (see clause 6), when viewed from the rear, and projected on the top edge of the guard.

## ISO 6533:2001(E)

### 5 Gauge dimensions

Rigid gauges of the types and sizes specified in Table 1 shall be used to determine the dimensions and clearances.

Table 1 — Gauge dimensions

Gauge type	Diameter $\pm 0,5$	Length $\pm 0,5$	Dimensions in millimetres
			Corner radius max.
A	35	100	5
B	70	100	0,5
C	56	82	0,5

### 6 Determination of reference point $X_0$

#### 6.1 Normal case

The reference point  $X_0$  shall be determined, when viewed from the rear, using a type A gauge kept furthest to the right side of the front handle, parallel to and directly below the centreline of the front handle, and in contact with both the handle and the top of the housing. See Figure 1, a) and b).

#### 6.2 Special case

When the machine design is such that a type A gauge of 100 mm length cannot be inserted between the handle and the housing, and  $X_0$  cannot be determined using such a gauge, the gauge length may be shortened (though by no more than is necessary). Using this modified gauge,  $X_0$  shall be determined according to all other requirements of 6.1. See Figure 1, c).

### 7 Front hand-guard dimensions

#### 7.1 Front hand-guard width, $W_1$

The front hand-guard width,  $W_1$ , is the distance from  $X_0$  to the point at which the requirement for the front hand-guard height over the front handle,  $H_1$  (see 7.2), is not fulfilled.

When the machine is viewed from the rear,  $W_1$  shall cover the front handle from  $X_0$  to a minimum of 100 mm to the left of  $X_0$  (see Figure 2).

Any part of the area defined by the outer contour of the front hand-guard and the housing shall be intersected by the line from  $X_0$  to the rearmost, upper unprotected part of the saw chain on the guide bar (see Figure 3).

#### 7.2 Front hand-guard height over front handle, $H_1$

The measurement of the vertical height  $H_1$  shall be made in a plane parallel to the guide bar plane and perpendicular to the guide bar centreline (see Figure 4).

Any free play in the guide bar fixing shall be taken up by tightening the guide bar to the saw body in its uppermost position.

$H_1$  shall be at least 20 mm above the upper surface at each point on the front handle over the length of  $W_1$  as specified in 7.1.

When the front hand-guard activates the chain brake, the minimum height shall be 0 mm, with the front hand-guard in the released position (see  $H_{1A}$  in Figure 4).

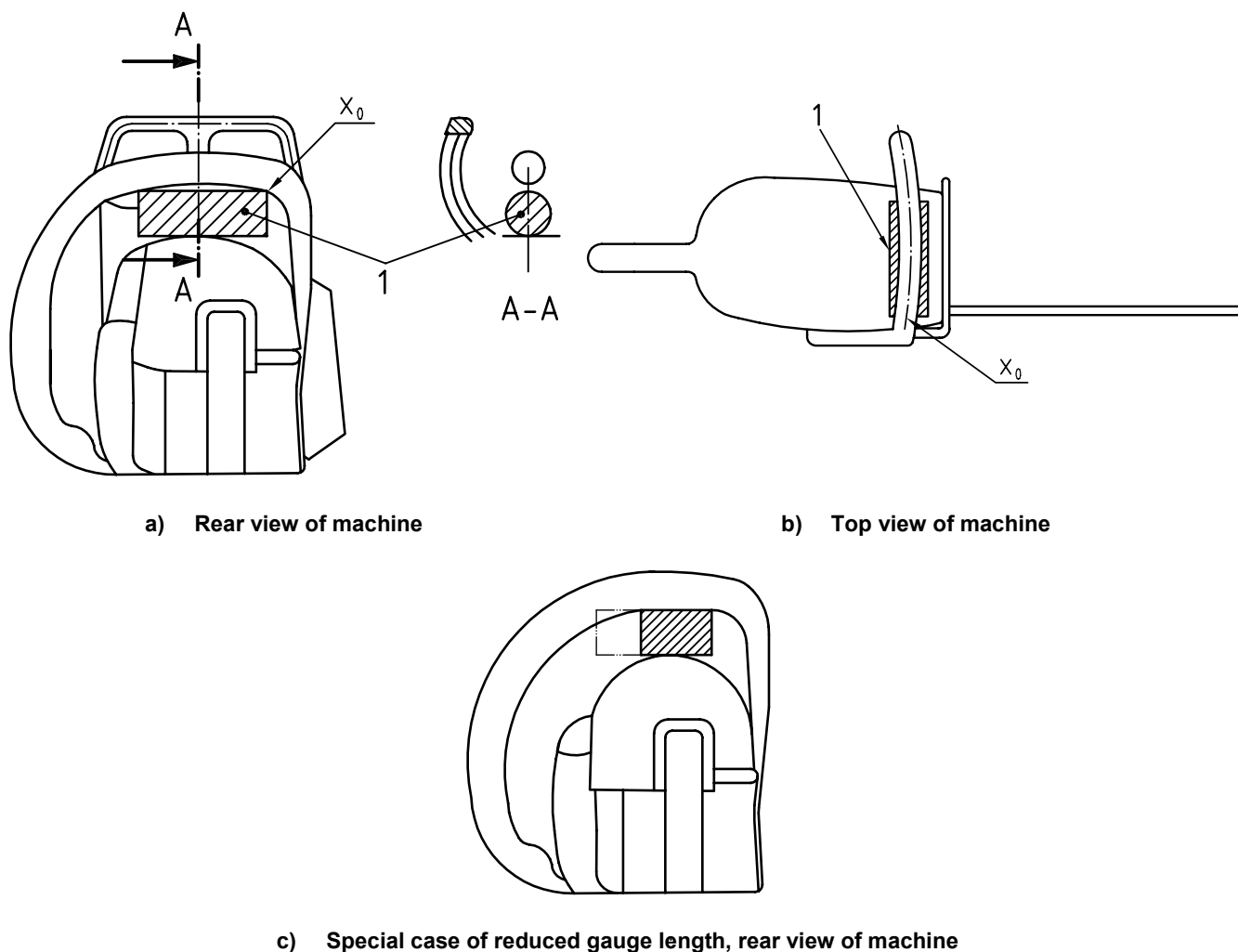

**Key**

1 Type A gauge

**Figure 1 — Definition of reference point  $X_0$**

## ISO 6533:2001(E)

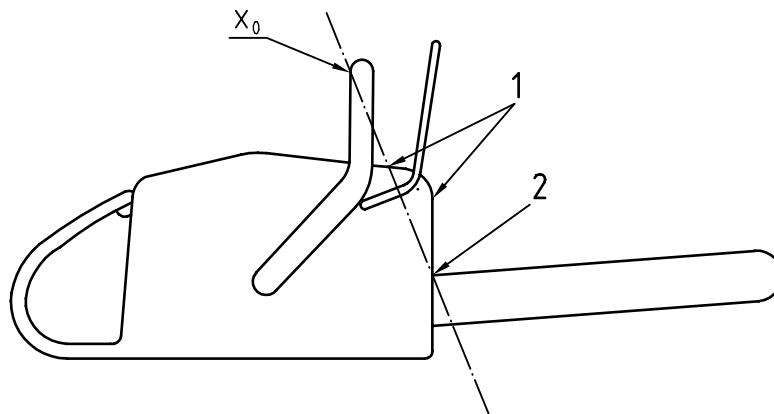
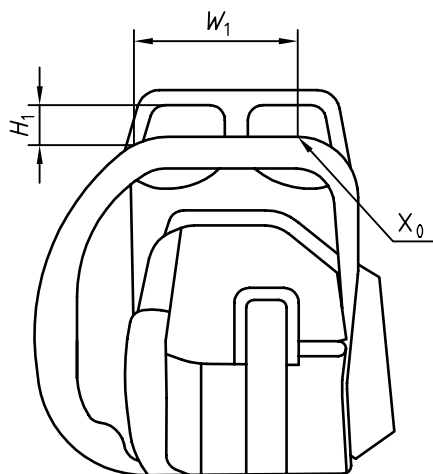

### Key

- 1 Intersection point
- 2 Intersection with unprotected part of chain saw

**Figure 2 — Front hand-guard width,  $W_1$ , rear view of machine**

**Figure 3 — Line between  $X_0$  and rearmost part of unprotected saw chain**

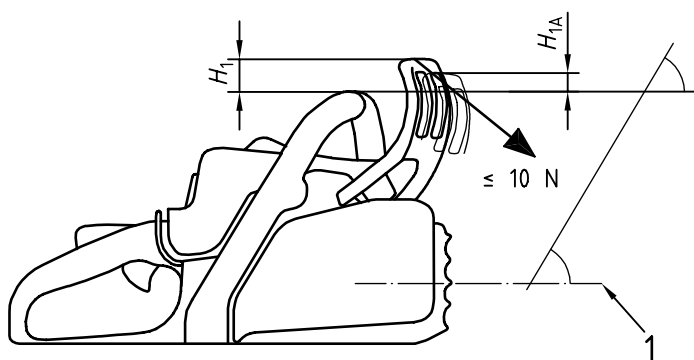

### Key

- 1 Centreline of guide bar

**Figure 4 — Front hand-guard height over front handle ( $H_1$  and  $H_{1A}$ ) — Machine viewed from right side**

### 7.3 Height of front hand-guard openings, $H_3$

The front hand-guard may have openings. Such openings shall be limited in height ( $H_3$ ) so that a type C gauge, applied in any direction and from either front or rear, cannot pass through when pushed forward perpendicularly to the face of the opening. See Figure 5.



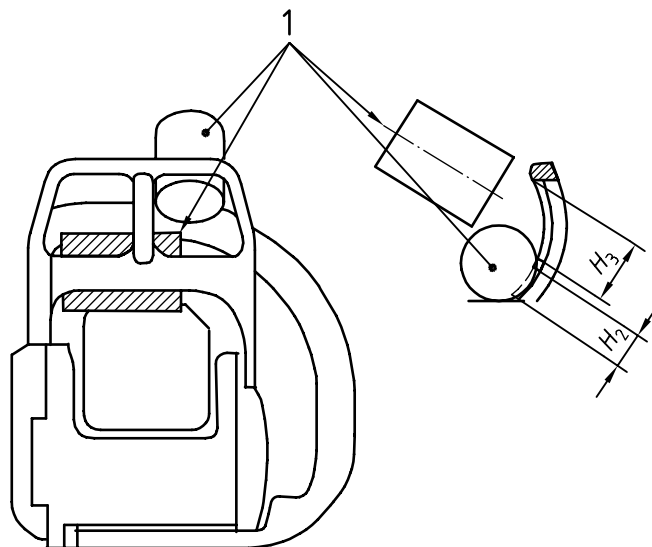

**Key**

- 1 Type C gauge

**Figure 5 — Front hand-guard openings,  $H_3$ , and clearance,  $H_2$ , between hand-guard and saw body — Machine front view**

### 8 Clearance between hand-guard and saw body, $H_2$

The clearance,  $H_2$ , between the lower edge of the front hand-guard and any component of the saw body shall be limited so that a type C gauge, held parallel to the front hand-guard, cannot pass through (see Figure 5). This limitation of the clearance applies to the entire width  $W_1$  (see 7.1).

If necessary, the gauge may be applied from the front, in which case additional means could be necessary for holding the hand-guard fixed in position.

### 9 Clearances between hand-guard and front handle, $R_1$ and $R_2$

There shall be a clearance between any part of the front hand-guard and the front handle, starting from  $X_0$  to the left when viewed from behind, such that

- a type A gauge can pass the clearance without coming into contact with the hand-guard ( $R_1$ ), and
- a type B gauge cannot pass the clearance and any part of the gauge centreline will come lower than any part of the centreline of the front handle ( $R_2$ ).

See Figure 6.

## ISO 6533:2001(E)

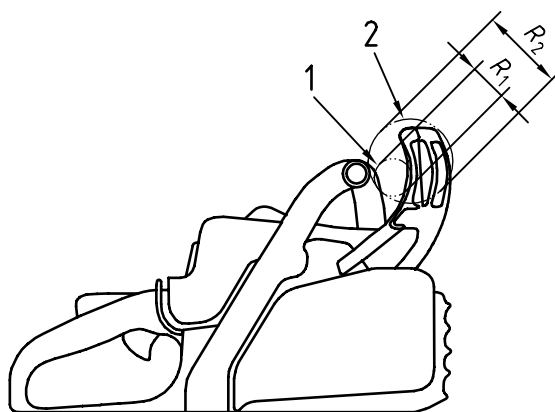

### Key

- 1 Type A gauge
- 2 Type B gauge

**Figure 6 — Clearances between front hand-guard and front handle ( $R_1$  and  $R_2$ ) —  
Machine viewed from right side**



## ISO 6533:2001(E)

---

---

**ICS 65.060.80**

Price based on 6 pages